



educated
furniture
built for learning

Volume 9 Catalogue



P 0508 645 397

E sales@educatedfurniture.co.nz

W educatedfurniture.co.nz

quality 

value 

service 



ABOUT US

Our business was born back in 1994 (formerly known as Mike's Woodshop) when we began manufacturing children's furniture and toys from a skyline garage in Poroti, New Zealand.

Upon offering our local Whangarei schools the opportunity to purchase some painting easels, one of the local principals asked if we could custom make something similar. We took up the challenge and since then we have grown and diversified from a small product offering to a comprehensive catalogue of custom built furniture manufactured in our Whangarei based factory, along with a wide range of complementary imported and locally sourced products.

We have a skilled and loyal team who take pride in the products we deliver and who strive to provide all our customers with quality, value and service.

We have a custom built factory in Whangarei with modern machinery that produces our product to a very high standard. Over the years we have also developed an importing side to our business, whereby we can provide a number of items direct to our customers at great prices, as well as quality components to help keep our products competitive in the market. All our imported products have been very carefully selected, ensuring that they are of a higher specification than any locally made product.

We also have a range of New Zealand suppliers that complement our own furniture to ensure we have a comprehensive range available. We are very loyal to our suppliers and therefore they support us and our customers.

As a customer of Educated Furniture you have our assurance that:

- Customer service and satisfaction is our priority
- We only use and supply top quality materials and our workmanship is at the highest level.
- We will bring you the best possible products at the most competitive prices.
- We can offer a customised design service - for all areas, including the classroom, staffroom, break out spaces, offices, administration areas and libraries.
- We manufacture furniture to your specifications.
- We are always happy to assist with designing and manufacturing bespoke equipment.
- We are always researching and testing new and innovative products that we can add to our product offering.
- We are always working on ways to improve our existing products as well as coming up with completely new designs where there is a gap in the market.

COMPANY CONTACTS



Oren Ellery | Managing Director
P 09 430 8000
M 027 270 2450
E oren@educatedfurniture.co.nz



Michael McCartain | Factory Manager
P 09 430 8000
M 021 324 379
E michael@educatedfurniture.co.nz



Debby de Vantier | Office Administrator and Sales Support
P 09 430 8000
E sales@educatedfurniture.co.nz



Graham Lyons | Auckland Account Manager
P 021 537 760
E graham@educatedfurniture.co.nz



Jono Mills | Lower North Island Account Manager
M 021 537 740
E jono@educatedfurniture.co.nz



TESTIMONIALS

I was first introduced to Mike's Woodshop in my first Principalship 9 years ago. I am now in my third Principalship and have proudly used Mike's Woodshop as our preferred and sole supplier of school furniture. The products from Mike's Woodshop are second to none and their range is extensive and suited today's classroom spaces and ever changing needs. The biggest reason I have used Mike's Woodshop is the fantastic service and relationship with Kerri and the team. Mike's Woodshop is 100% kiwi owned and their business is incredibly personalised. Kerri and the team treat you like old friends and ensure that service is never compromised. Their vast knowledge of furniture and classroom design supports your decision with maximising purchasing the best furniture and value for dollar. Recently, I introduced my new DP to Mike's Woodshop and she was wowed by their product and range. I can 100% endorse Mike's Woodshop as the premium supplier of school furniture.

Regan Orr | Principal Central Normal School | Te Kura Tuatahi o Papaioea, Palmerston North

Quality product complimented by quality service. It's great to have such value-add for the product and service offered by Mike's Woodshop. I go straight to Mike's Woodshop as I can't fault the service, advice and products.

John Petrie | Principal Huapai District School, Auckland

We have been using Mike's Woodshop for many years for the furniture requirements for our school. We are always happy with Mike's Woodshop, staff and the products. They are truly amazing, the staff are approachable, are always happy to help and have great follow up service.

Lesley Campbell | Office Manager Puhinui School, Auckland

Our school has been a satisfied customer of Mike and Kerri's for many years. We have always found them to be helpful, accommodating and prompt to deal with. Their products always look great in our classrooms and learning spaces, it certainly stands up to the rigors of our modern learning environments.

Steve Graveson | Property Manager Katikati Primary School, Katikati

Parua Bay School has purchased a range of diverse furniture from Mike's Woodshop for many years. Nothing is ever too much trouble for Kerri and Mike and their focus is always on what we need as a school. Their service is prompt and friendly and we have always been satisfied with their high quality products.

Danny Jewell | Principal Parua Bay School, Northland

We have been a customer of Mike and Kerri for many years. Their products are good and their service is as well. We have never had any problems, and their integrity is beyond reproach.

Pat Newman | Principal Hora Hora School, Whangarei

I have known Mike and Kerri from Mike's Woodshop since 1995. The quality of products and the advice and guidance from Mike, Kerri and the team at Mike's Woodshop are unquestionably second to none. I have moved around the country and have been the Principal in a variety of schools since 1995. I continue to purchase my school furniture from Mike and have never been let down by quality or price. My advice to any principal looking to purchase school furniture is to get a quote from Mike. You will save money and your children will benefit from excellent furniture.

Colin Watkins | Principal Westbrook School, Rotorua

I have purchased products from Mike's Woodshop since 1998, in my capacity as principal of four schools and as a member of the Whangarei and Tai Tokerau Principals' Associations. A hallmark of their service is their clear, quick and personal communication. Mike, Kerri and the staff are always available and prepared to discuss needs and to help create options where something different is required. They establish positive relationships with key people in the school. Both Mike and Kerri are extremely knowledgeable about school environments and the ever changing needs of schools. Mike's Woodshop have been sponsors of the Tai Tokerau Principals' Association since its inception. Their support of the annual TTPA Conference is valued and they fully embrace the philosophy of the conference - networking. The products they provide are of high quality, competitively priced and backed up by an experienced and hardworking team.

Paul Shepherd | Principal Maunu Primary School, Whangarei

MIKE'S WOODSHOP LTD - OFFERS YOU

- Customer service and satisfaction is a priority
- That we will continue to use top quality materials and our workmanship will be at the highest level
- We will bring to you the customer, the best possible product at the most competitive price
- As an importer, we are able to bring to you products at wholesale rates, cutting out the middle man
- A customised design service – for all areas, including the classroom, staffroom, break out spaces, Administrations, Libraries, etc
- As the manufacturer we are able to manufacture furniture to your specifications
- We will be constantly increasing our range of furniture available to you
- Don't be afraid to ask for something that will be unique to your requirements.
- Due to improvements to any product, size and changes may occur without notice

Guarantee

- We offer you a 10 year guarantee on all products unless stated otherwise on a particular item
- The guarantee covers faulty materials and workmanship only
- The guarantee does not cover unfair wear, tear, misuse or abuse
- The guarantee does not cover any fabrics or zips unless stated on the individual product
- Our guarantee is a return to base guarantee. Should in the unlikely event an item fails within the specified guarantee period it is up to the customer to return this to Mike's Woodshop for repair. Once the item is repaired we will pay the cost to return to you

Samples

- We are happy to supply samples where necessary. This is on a 7 day trial. The goods must be returned to us in a "new" condition at the cost of the client.

TERMS & CONDITIONS

Delivery

- All goods received must be checked before signing for
- If there has been any damage to the goods delivered this **MUST** be written on the delivery consignment note. It is also easier and quicker for everyone if you leave the item on the truck so that it can be replaced or repaired and back to you as soon as possible.
- Once signed for, no matter the condition, it is yours. So please check all inwards goods properly before signing for them.

Returns

- Any goods needing to be returned for any reason, you must have written permission from Mike's Woodshop Ltd. If returned without permission, there may be costs incurred by you.
- All goods have been made to your specifications. You have made your personal choices of colours, sizes and items and these have been made especially for you. All of these items are non-returnable
- If the goods have not been made to the specification on the website, catalogue or quote we are happy to have them replaced with the correct product.
- If we agree to have any goods returned there will be a restocking fee and a freight cost.

Specials

- Any items that are 'made to your specifications are not returnable.

Romalpa Clause

- Title on the goods supplied does not pass to the purchaser until payment has been made in full.

Bad Debts

- Any accounts not paid in full maybe given to a debt collector.
- All costs incurred will be payable by you the customer

Terms of Payment

- Payment required by the 20th of the month following the invoice.
- If you do have an account with us, goods must be paid for before they are dispatched.

Pricing

- All prices are subject to change without prior notice.
- All prices are PLUS GST and freight.

Disclaimer

- On publishing all items are correct to specification and design.
- However some items may differ due to updating a design and the availability of the raw materials
- Suppliers update their products from time to time, so replacement product may occur.
- We have endeavoured to have all the information correct at time of printing, however any mistakes that have been made will be pointed out to the client at time of purchase.
- All colours pictured are as close as we can get as the printing process will allow.

CONTENTS

Educational Units

Whiteboard Cabinets	9-12
Teacher Stations	13-14
Tablet Storage	15
Laptop Storage	16
Teachers Podiums.....	17
Book Displays	18-20
Mobile Book Storage	21-22
Multi Storage.....	23-24
Serpentine Range	25-26
Tote Trolleys.....	27
Tote Trolley Storage.....	28
Multi Units.....	29-30
Cubbyholes	31
Bag Storage	32
Art Storage.....	33-34
Cupboards & Sickbay Beds.....	35

Tables & Desks

Tables	37-38
Jellybean Table	39
Horseshoe Tables.....	40
Tall Tables.....	41
Swerve Tables	42
Omega Tables.....	43
Switch Tables.....	44
Sigma Tables	45
'O's and Bows Tables	46
Gamma & Delta Tables.....	47
Alpha & Tables.....	48
Shaped Tables	49
Study Carrels.....	50
School Desks.....	51-52
Computer Tables.....	53
Technology Tables.....	54
Teachers Desks	55
Folding Tables & Trolleys.....	56

Seating

Summit Chairs.....	59-60
--------------------	-------

Rainbow Chairs.....	61
Titan Chairs	62
Stools.....	63-65
Cafe Stools & Chairs	66-68
Linking Chairs.....	69
Guest Chairs.....	70-76
Office Chairs.....	77-80
Office Stools	80-81
Chair Mats & Footrests.....	81

Soft Furnishings

Fritters, Bean Bags & Stools	83-84
Ottomans	85-88
Couches.....	89-91

Office Furniture

iQuad Office Furniture	93-94
Workstations & Desks	95-98
Reception & Library Desks.....	99
Ergonomic Desking & Accessories ...	100-102
iQuad Desk Units	103
iQuad Mobiles & Credenzas.....	104
iQuad Storage.....	105-106
Modular Units	107-108
Meeting Tables	109-110
Bar Leaners.....	111
Coffee Tables.....	112
Europlan.....	113-114

Whiteboards, Pinboards & Partitions etc

Autex	116
Whiteboards & Pinboards	117-120
Office Partitioning & Screens	121-123
Stages & Lecturns.....	124
Lundia Shelving	125-126
Glass Cabinets.....	127

Colour Charts

Fabrics	128-132
Melteca.....	133-134
Powder Coating	134







PROPOSAL CLASSROOM FOR 32 CHILDREN

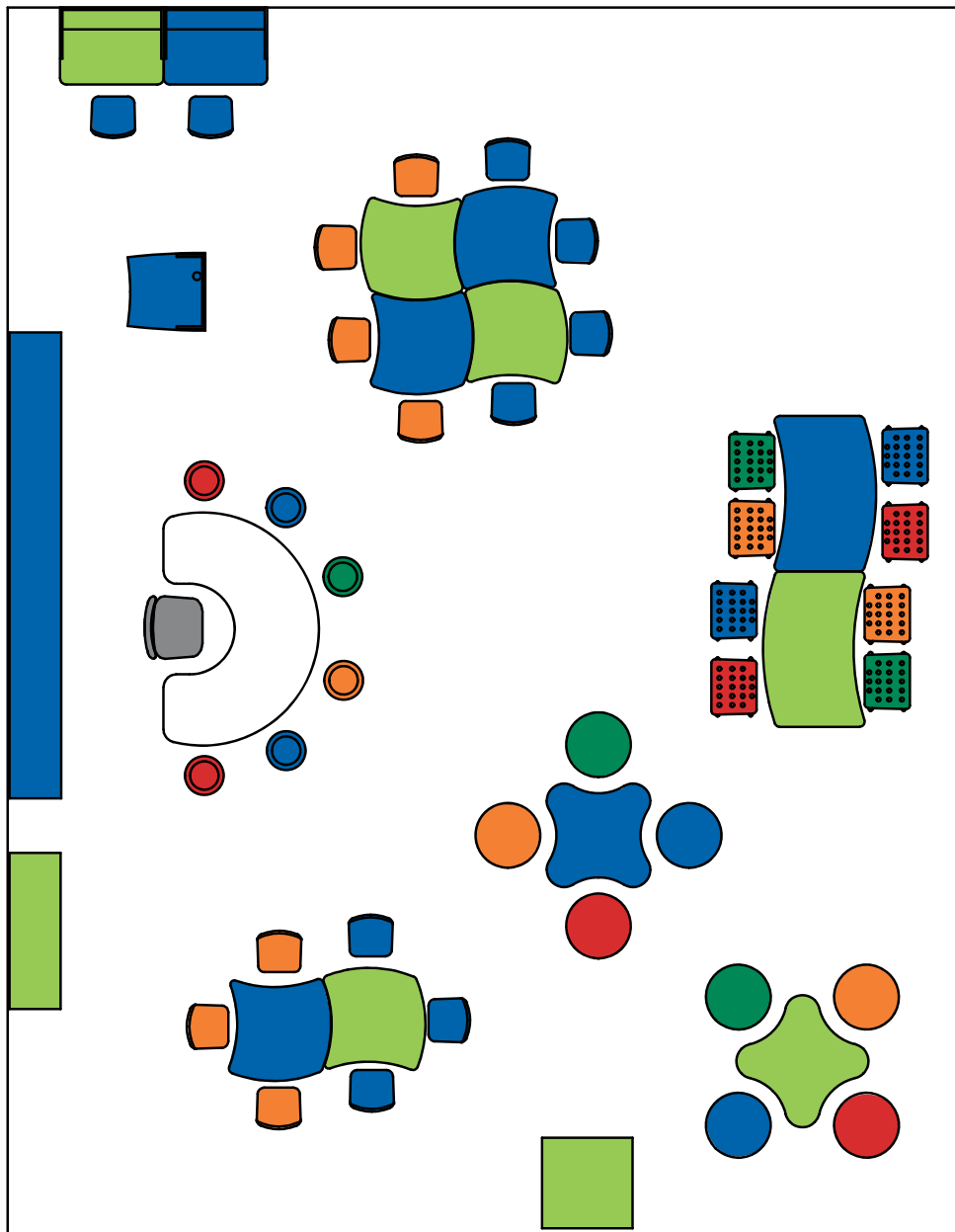

STORAGE	TEACHER	CHILDREN TABLES	CHILDREN SEATS
Whiteboard cabinet	Buro Mario Chair	6 x Switch tables	10 x Summit chairs
2400L or 3600L	Horseshoe table	2 x Study carrels	6 x Move 'n' Rock stools
Podium	Buro Roma office chair	2 x Alpha 4 kneeler	8 x Fritters
Library Tower	6 x Move 'n' Rock Stools	2 x Tall table	8 x Pepper stools
Tote tray storage			

ALTERNATIVE PRODUCTS

Serpentine Units	Jellybean table	Omega tables	Rainbow chairs
Storage seats	6 x Move 'n' Rock stools	"O" and Bow tables	Titan chairs
Book display	6 x Rainbow chairs	Swerve tables	Bean bags
Teachers stations	6 x Summit chairs	Sigma tables	MLE stools
Tote trolleys	6 x Titan chairs	Kneeler tables	

PROPOSAL CLASSROOM FOR 24 CHILDREN

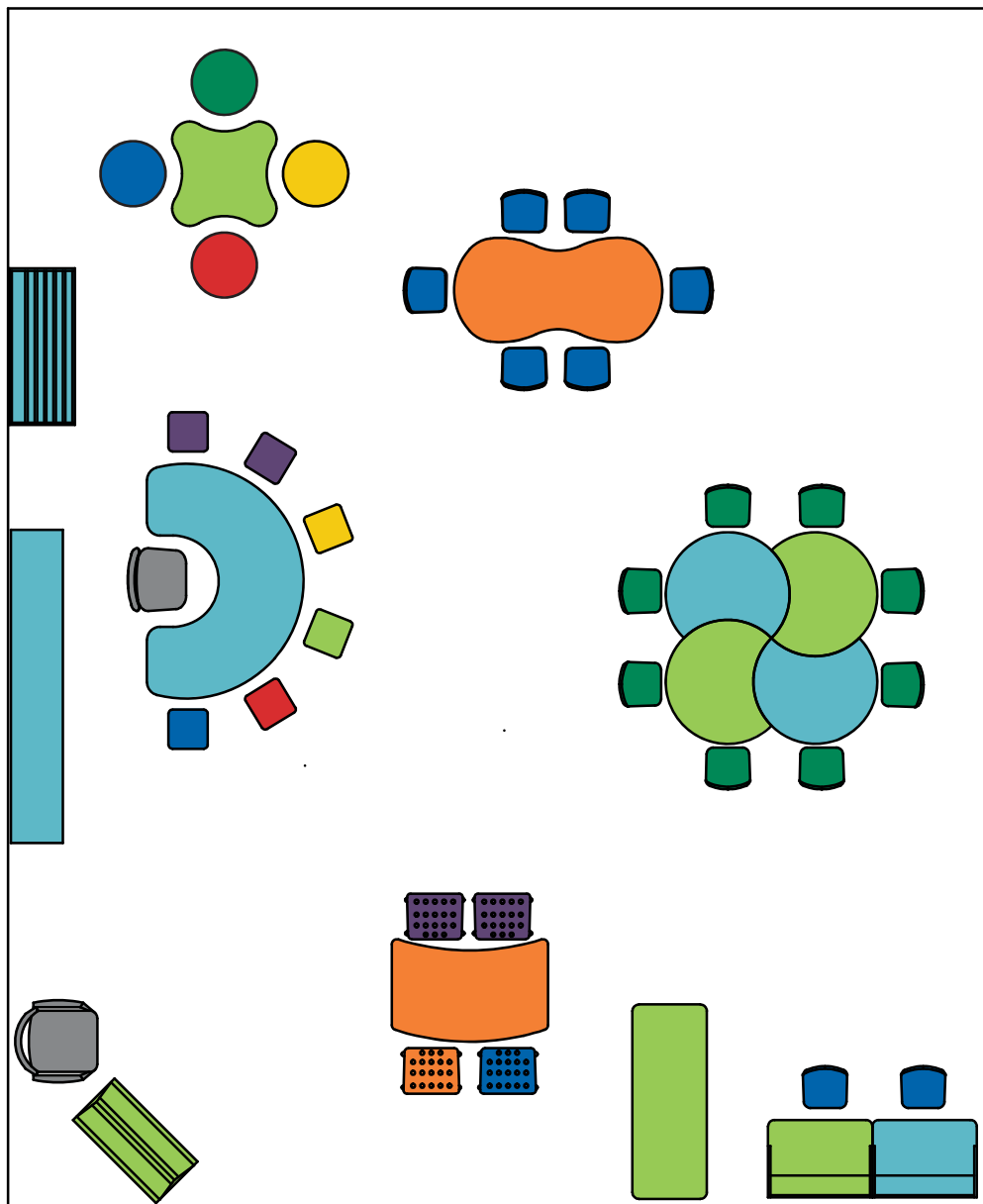

STORAGE	TEACHER	CHILDREN TABLES	CHILDREN SEATS
Whiteboard cabinet	Buro Mario Chair	4 x Omega tables	8 x Summit chairs
2400L or 3600L	Horseshoe table	1 x Omega connecta	4 x Move 'n' Rock stools
Book Display	Buro Roma office chair	1 x Alpha 4 kneeler	4 x Fritters
Tote tray storage	6 x MLE Stools	1 x Tall table	2 x Summit chairs
Teachers Station		2 x Study carrels	

ALTERNATIVE PRODUCTS

Podium	Jellybean table	Switch tables	Rainbow chairs
Library Tower	6 x Move 'n' Rock stools	"O" and Bow tables	Titan chairs
Serpentine units	6 x Rainbow chairs	Swerve tables	Bean bags
Storage seats	6 x Summit chairs	Sigma tables	MLE stools
	6 x Titan chairs	Kneeler tables	





EDUCATIONAL UNITS

CONTENTS

Whiteboard Cabinets	9-12
Teacher Stations	13-14
Tablet Storage	15
Laptop Storage	16
Teacher Work Podiums	17
Book Displays.....	18-20
Mobile Book Storage	21-22
Multi Storage.....	23-24
Serpentine Range	25-26
Tote Trolleys.....	27
Tote Tray Storage	28
Multi Units.....	29-30
Cubbyholes	31
Bag Storage.....	32
Art Storage	33-34
Cupboards.....	35
Sickbay Beds.....	35

915 WHITEBOARD CABINETS

Optimise your storage with a practical and useable storage system, customised to your individual needs. We have a range of cabinet bases that include cupboards, drawers, cube crates & tote trays which enhance your unit, with the upper levels having adjustable shelving, hiding behind the sliding whiteboards.

Pick the sizes you require to make up the overall measurement, keeping this within the 1800, 2400, 3000, 3600 & 4800mm lengths.



2400L x 400d x 2000h
2400 Whiteboards
1 x Unit R
1 x Unit C
1 x Unit A

All units are 2000 high x 400 deep with the interior shelf depth in the top section 290mm. Some of the width sizes may vary depending on your combinations. Now also the option for the 600 deep cabinets.

The cabinet incorporates aluminium framed sliding whiteboards that have a porcelain surface, complete with a Forever Surface guarantee. You can also upgrade for the new Porcelain Projection Boards.

This is a modular system that can be shipped throughout NZ, and very easily assembled on site.



Standard Sizes

- 1800L x 400d x 2000h – with 2 900x1200 porcelain whiteboards
- 2400L x 400d x 2000h – with 2 1200x1200 porcelain whiteboards
- 3000L x 400d x 2000h – with 2 1500x1500 porcelain whiteboards
- 3600L x 400d x 2000h – with 2 1800x1200 porcelain whiteboards
- 4800L x 400d x 2000h – with 2 2400x2200 porcelain whiteboards

We can customise these sizes to fit your individual requirements. Locks are available on the whiteboards, cupboards & drawers on request

Upgrade to Porcelain Projection board

Enhanced Projection Whiteboards

Ideal for spaces that are exposed to excessive ambient light, Porcelain Projection board scientifically engineered to reduce glare. Whether utilised with short throw, long throw or interactive projectors, Porcelain Projection Boards minimizes visual stress from anywhere in the room.

FEATURES

- Chemical Resistant
- Scratch Resistant
- Bacteria Resistant
- Fire Resistant
- Stain Resistant



High-gloss whiteboard surface



Porcelain Projection board

All 2000mm high and 400mm deep

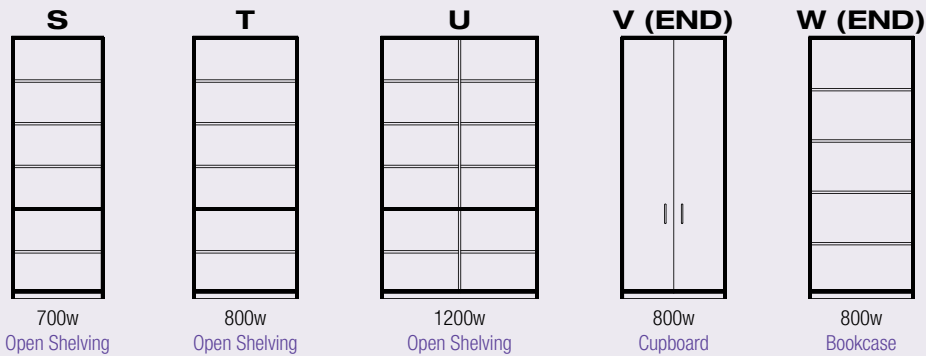
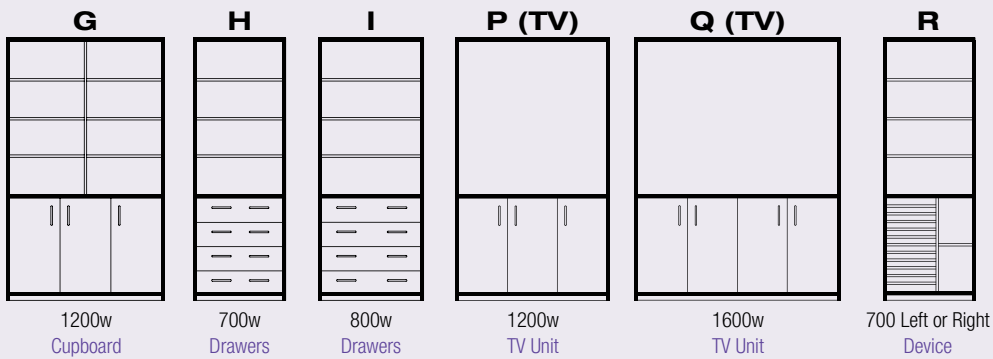
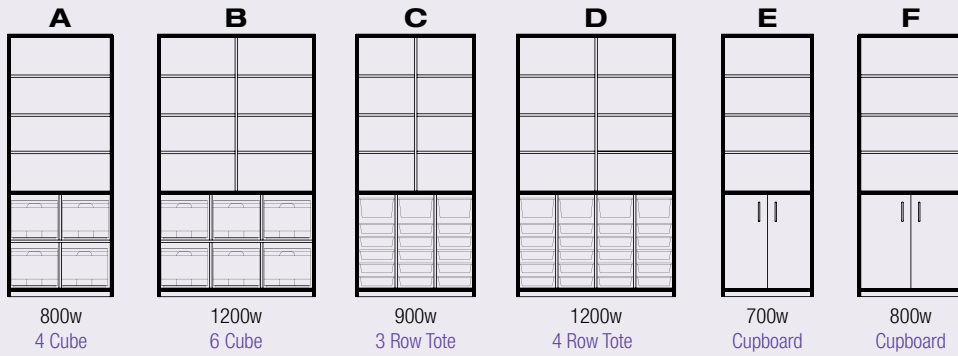

EXTRAS

Add locks to doors & drawers

Add locks to whiteboards for security of TV's etc

Tote trays small & large blue, red, grey & clear

Cube crates blue or clear



4000L x 2000H x 400D

- 1 X Unit V Cupboard
- 3200 Whiteboards
- 1 x Unit B
- 1 x Unit D
- 1 x Unit F
- + Tote Trays and Cube Bins



2400L x 2000H x 400D

- 2400 Whiteboards
- 1 x Unit B
- 1 x Unit P
- + Cube Bins



2600L x 2000H x 400D

- 2600 Whiteboards
- 1 x Unit C
- 1 x Unit F
- 1 x Unit C
- + Tote Trays

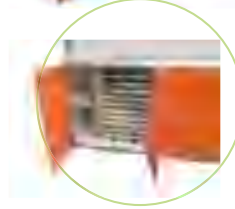

3000L x 2000H x 400D

- 3000 Whiteboards
- 1 x Unit H
- 1 x Unit A
- 1 x Unit F
- 1 x Unit R



2400L x 2000H x 400D

- 2400 Whiteboards
- 2 x Unit F
- 1 x Unit I
- Add Gridding



3600L x 2000H x 400D

- 3600 Whiteboards
- 1 x Unit R
- 1 x Unit G
- 1 x Unit C
- 1 x Unit I
- + Tote Trays



As you can see, this is a very versatile range with lots of ideas to mix & match to suit your individual needs & requirements

KERRI'S KOLOURS



Memphis Blue

Memphis Red

Memphis Green

Energise

Juicy

Caribbean

Olympia Yellow

Storm

BIRCHWOOD RANGE

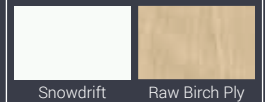

Snowdrift

Raw Birch Ply



945 WHITEBOARD CABINETS - 600mm deep

The 600mm deep cabinets have been developed & designed for mainly Technology, Food Tech, Art & Science rooms. Needing the depth to store the more bulkier items. Base cabinets are 600mm deep with shelving behind the whiteboards being 490mm. All shelves are adjustable.

All 2000h and 600mm deep

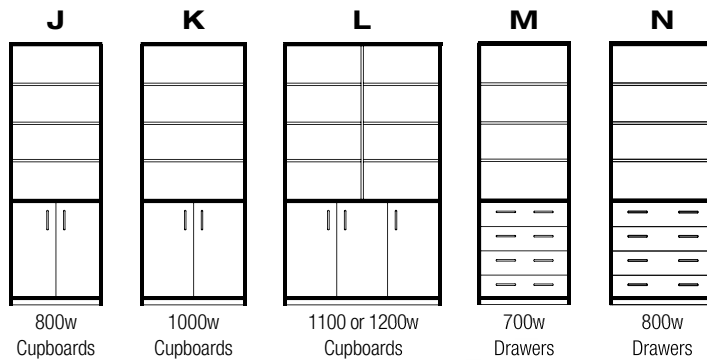

Standard Sizes

- 1800L x 600d x 2000h – with 2 900x1200 porcelain whiteboards
- 2400L x 600d x 2000h – with 2 1200x1200 porcelain whiteboards
- 3000L x 600d x 2000h – with 2 1500x1500 porcelain whiteboards
- 3600L x 600d x 2000h – with 2 1800x1200 porcelain whiteboards
- 4800L x 600d x 2000h – with 2 2400x2200 porcelain whiteboards

We can customise these sizes to fit your individual requirements.
Locks are available on the whiteboards, cupboards & drawers on request

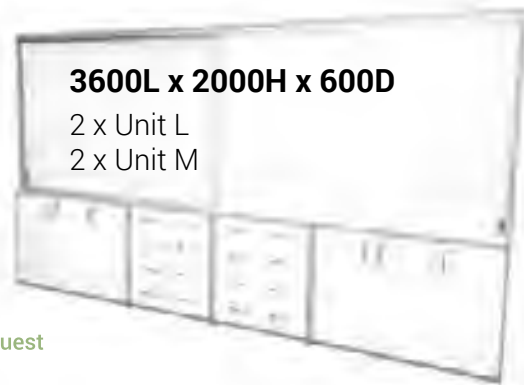

STANDARD COLOURS

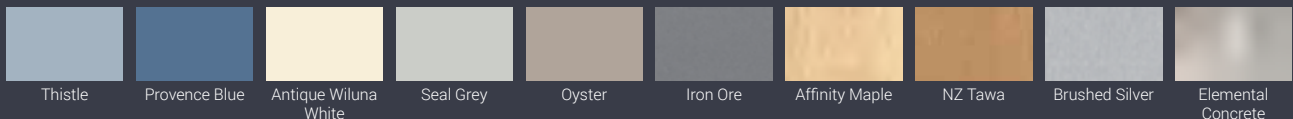

See inside back cover for more choices

STANDARD OPTIONS

- Magnetic whiteboard on both sides
- Replace one whiteboard with a pinboard - Grey or Blue



OPTIONAL EXTRAS

- To have one side with a vertiface pinboard. This is also velcro compatible.
- Standard colour - Ink. Other colours available on quantity orders

1 TEACHER STATION



Base Size - 900L x 450D x 550H
Total Height - 1150mm

- Industrial rubber wheeled castors
- Board size 900mm x 600mm
- Drawer access from both sides
- Clips on both sides

4 TEACHER STATION



Base Size - 900L x 450D x 550H
Total Height - 1150mm

- Industrial rubber wheeled castors
- Board size 900mm x 600mm
- Drawer access from both sides
- Clips on both sides

7 TEACHER STATION



Base Size - 900L x 450D x 550H
Total Height - 1150mm

- Industrial rubber wheeled castors
- Board size 900mm x 600mm
- Drawer access from both sides
- Clips on both sides • 1 locking cupboard

73 TEACHER STATION



Base Size - 900L x 450D x 550H
Total Height - 1150mm

- Industrial rubber wheeled castors
- Board size 900mm x 600mm
- Clips on both sides
- Complete with 3 small & 3 large tote trays

KERRI'S KOLOURS



Memphis Blue

Memphis Red

Memphis Green

Energise

Juicy

Caribbean

Olympia Yellow

Storm

BIRCHWOOD RANGE

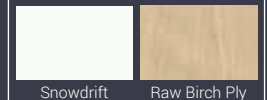

Snowdrift

Raw Birch Ply

74 TEACHER STATION/TV



A

A - Base Size - 1000L x 450D x 700H
Total Height - 1300mm

- Industrial rubber wheeled castors
- One Side**
 - Backboard ready to attach 1000x600 flat screen TV (40")
 - Cable ports for easy cord access
 - Pullout shelf for laptop
 - Space for DVD player
- Other Side**
 - Complete with whiteboard, 900x600
 - Base fits 2 large, 4 small tote trays & 1 adjustable shelf
 - Bracket, TV, Laptop etc not included



B

B - Base Size - 1200L x 450D x 750H
Total Height - 1560mm

- Industrial rubber wheeled castors
- One Side**
 - Backboard ready to attach 1200x800 flat screen TV (50")
 - Cable ports for easy cord access
 - Pullout shelf for laptop
 - Space for DVD player
- Other Side**
 - Complete with whiteboard, 1200x800
 - Base fits 2 large, 4 small tote trays & 1 adjustable shelf
 - Bracket, TV, Laptop etc not included

5 TEACHER STATION



Base Size - 900L x 450D x 700H
Total Height - 1300mm

- Industrial rubber wheeled castors
- Board size 900mm x 600mm
- Drawer access from both sides
- Clips on both sides

72 TEACHER STATION



Base Size - 900L x 450D x 700H
Total Height - 1300mm

- Industrial rubber wheeled castors
- Board size 900mm x 600mm
- Clips on both sides
- Complete with 4 large & 4 small tote trays

STANDARD COLOURS

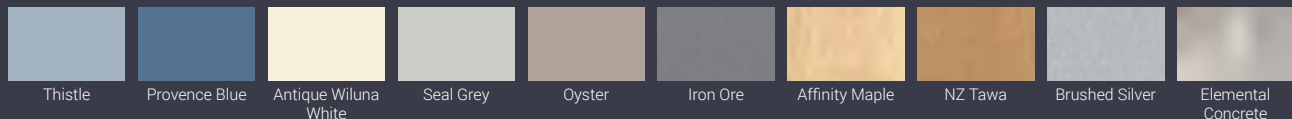

See inside back cover for more choices

Thistle

Provence Blue

Antique Wiluna
White

Seal Grey

Oyster

Iron Ore

Affinity Maple

NZ Tawa

Brushed Silver

Elemental
Concrete

420 IPAD & CHROME BOOK STORAGE UNIT

- Size of slot 260W x 35D x 250H - Maximum Height 425mm
- Mount your Powerpack & plugs on the back and thread the plugs through the cable port holes
- Looks like a cupboard, not like it has \$1000's worth of iPads inside
- Complete with locks



2 Row Unit

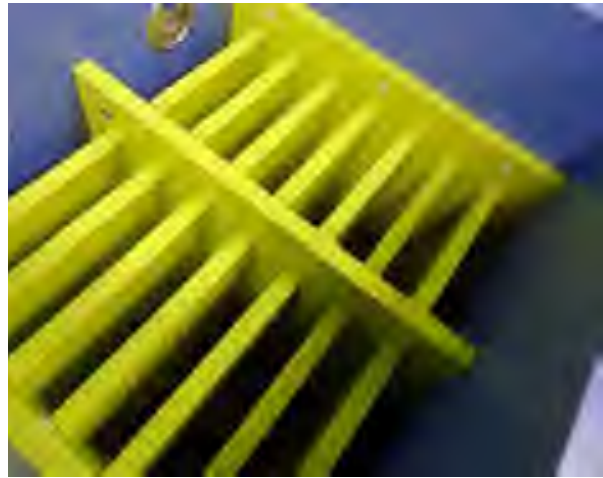

A - 2 rows - stores 16 Chrome Books 620W x 600D x 725H



3 Row Unit



ADD POWER PACKS (IF REQUIRED)

- Includes surge protection
- Available for all units

B - 3 rows - stores 24 Chrome Books 840W x 600D x 725H



4 Row Unit



C - 4 rows - stores 32 Chrome Books 1175W x 600D x 725H

KERRI'S KOLOURS



BIRCHWOOD RANGE

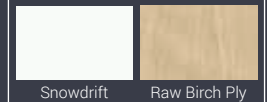

400 LAPTOP STORAGE 24 & 30

- Heavy duty locking castors bolted through base
- Store 12 or 15 laptops each side
- Holes for all cabling including power cords at back
- Heavy duty handle on 1 end
- Grills for ventilation

We can add the power boards if required
- including surge protection



- A** Holds 24 - 1200L x 1100H x 500D
- Slot size - 395W x 395D x 60H
- B** Holds 30 - 1200L x 1180H x 500D
- Slot size - 395W x 395D x 50H

401 LAPTOP STORAGE 12 & 15

- Heavy duty locking castors bolted through base
- Store 12 or 15 laptops
- Holes for all cabling including power cables at back
- Heavy duty handle on 1 end
- Grills for ventilation

We can add the power boards if required
- including surge protection

- A** Holds 12 - 800L x 1100H x 500D
- Slot size - 395W x 395D x 60H
- B** Holds 15 - 800L x 1180H x 500D
- Slot size - 395W x 395D x 50H



STANDARD COLOURS

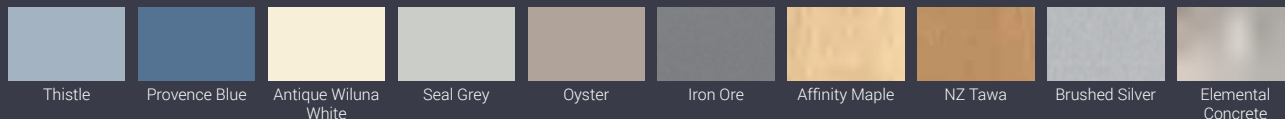

See inside back cover for more choices

501 TEACHER WORK PODIUM

Size

- 600W x 600D x 1000mm high (to work top)
- Plus 120mm high upstand

Specifications

- Shaped curved top with 120mm high upstand
- Decorative front panel
- 4 outlet power box with surge protector
- Plug can exit left or right hand side
- Pull out shelf on heavy duty runners with upstand at back
- 1 heavy duty drawer 120mm deep
- 1 cupboard with 1 adjustable shelf
- 75mm heavy duty locking castors
- Complete with locks on drawer & cupboard



KERRI'S KOLOURS



Memphis Blue

Memphis Red

Memphis Green

Energise

Juicy

Caribbean

Olympia Yellow

Storm

BIRCHWOOD RANGE

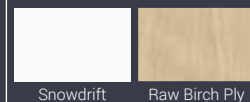

Snowdrift

Raw Birch Ply

17 SEVEN TIER BOOK DISPLAY



1200L x 960H x 500D

- 7 tier book display
- 1 shelf storage
- Solid matching back
- Industrial rubber wheeled castors

Optional Extras - Pinboard Backing

- Vertiface
- Blue or Grey fabric board

18 SIX TIER BOOK DISPLAY



1200L x 1000H x 500D

- 6 tier book display
- 2 shelf storage
- Solid matching back
- Industrial rubber wheeled castors

Optional Extras - Pinboard Backing

- Vertiface
- Blue or Grey fabric board

61 LIBRARY TOWER



1300H x 700D x 700L

- 4 sided display unit
- 3 adjustable shelves per side
- Industrial rubber wheeled locking castors

16 TEN TIER BOOK DISPLAY



1200L x 1300H x 550D

- 10 tier book display
- 1 shelf storage
- Solid matching back
- Industrial rubber wheeled castors

Optional Extras - Pinboard Backing

- Vertiface
- Blue or Grey fabric board

STANDARD COLOURS

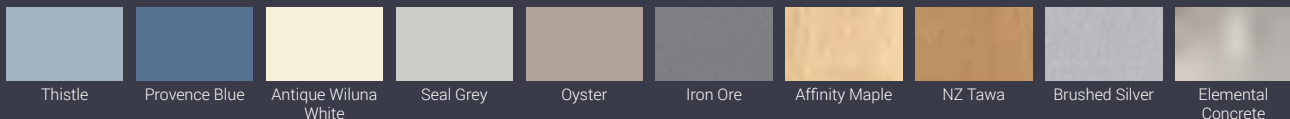

See inside back cover for more choices

11 DOUBLE SIDED DISPLAY



- 1200L x 1300H x 750D
- 7 tier book display / shelving on one side
 - 2 sloping / tote trays etc on reverse
 - Ideal in a library for new books, puzzles games & toys
 - Industrial rubber wheeled castors

312 DOUBLE SIDED DISPLAY



- 1200L x 1000H x 750D
- 7 tiered display and shelf
 - Storage on reverse
 - Industrial rubber wheeled castors

13 PICTURE BOOK DISPLAY



- 1200L x 450D x 1300H
- Large upstands (300mm)
 - 5 tier display
 - Suitable for larger books
 - Industrial rubber wheeled castors
 - Solid matching back

15 JUNIOR BOOK DISPLAY



- 1200L x 800H x 500D
- 7 tier book display
 - Industrial rubber wheeled castors
 - Solid matching back

KERRI'S KOLOURS



Memphis Blue



Memphis Red



Memphis Green



Energise



Juicy



Caribbean



Olympia Yellow



Storm

BIRCHWOOD RANGE



Snowdrift

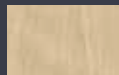

Raw Birch Ply

LIBRARY SHELVING

"Library Shelving - Made to Fit." Practical, user friendly & made to your individual sizes & requirements. New ideas every time!! Most importantly, it's cost effective!

64 LIBRARY SHELVING WITH BROWSER BOXES



A



B

A 1200W x 1500H x 400D

- Sloping top shelf
- 1 fixed & 1 adjustable shelf
- Solid 18mm back & central divisions
- Complete with 2 mobile browser bins
- Pictured with 2 units together

B 800W x 1500H x 400D

- Sloping top shelf
- 1 fixed & 1 adjustable shelf
- Solid 18mm back
- Complete with mobile browser bin in base
- Pictured with 3 units together

65 LIBRARY SHELVING



A



B

A 1200W x 1500H x 300D

- Sloping top shelf
- 3 adjustable shelves
- Central division
- Solid 18mm back
- Plinth base
- Pictured with multiple units in a row

B 800W x 1500H x 300D

- Sloping top shelf
- 3 adjustable shelves
- Solid 18mm back
- Plinth base
- Pictured with 2 units together

STANDARD COLOURS

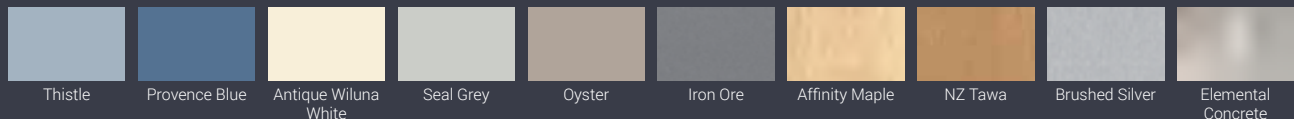

Thistle

Provence Blue

Antique Wiluna
White

Seal Grey

Oyster

Iron Ore

Affinity Maple

NZ Tawa

Brushed Silver

Elemental
Concrete

See inside back cover for more choices

28 SMALL BROWSER BOX



A 600L x 600D x 310H

- Twin wheel castors

B 700L x 600D x 310H

- To fit larger picture books

425 BOOK RETURN TROLLEY



1050H x 820L x 470W

- Mobile
- 32mm round steel frame
- Heavy duty castors

249 BOOK RETURN BIN



A 500 x 500 x 500 high

- Twin wheel castors
- To fit under returns desk

B Option

- Add drawer

148 MAGAZINE DISPLAY



640W x 370D x 1200H

- Mobile
- Powder coated in silver
- Wire bins to slip in magazines and pamphlets

KERRI'S KOLOURS



Memphis Blue

Memphis Red

Memphis Green

Energise

Juicy

Caribbean

Olympia Yellow

Storm

BIRCHWOOD RANGE

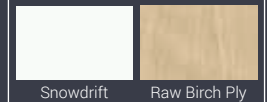

Snowdrift

Raw Birch Ply

380 MOBILE BIG BOOK BIN



- 600L x 600W x 570/420H
- 5 gaps to hold big books
 - Industrial rubber wheeled castors

76 JUMBO BIG BOOK STORAGE



- 1000L x 600D x 760/900H
- Top to fit big books standing up
 - Base to fit big books laying down
 - Industrial rubber wheeled castors
 - Large storage capacity for big books

24 BIG BOOK STORAGE



- 640L x 400D x 900H
- Industrial rubber wheeled castors
 - Solid matching back

57 MOBILE BINS



- A** 1200L x 390H x 400D (3 bins)
- Industrial rubber wheeled castors

- B** 1800L x 390H x 400D (4 bins)
- Industrial rubber wheeled castors

STANDARD COLOURS

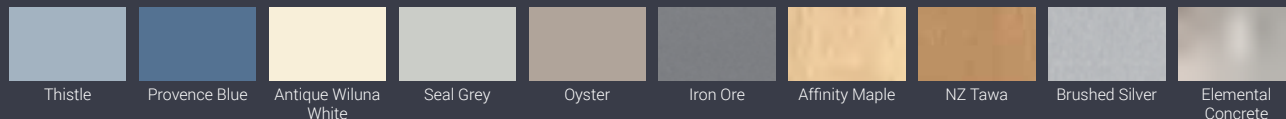

See inside back cover for more choices

385 MOBILE STORAGE BINS



500L x 400D x 420H

- Can be made to size
- Great for books, toys, blocks, lego etc
- Industrial rubber wheeled locking castors

22 BUDGET BOOK SHELF



All 800W x 300D

A 900H

B 1200H

C 1500H

D 1800H

- 18mm Melteca construction
- Adjustable shelves
- Additional shelves available

562 DRESS UP TROLLEY



1200L x 400D x 1200H

- Heavy duty castors
- Double side row of hooks
- 8 hooks each side
- Comes complete with 3 cube crates

567 LUNCH BOX TROLLEY



1200L x 600D x 900H

A 2 shelves - fit 20-24

B 2 shelves - fit 30-36

- Steel frame with 32mm round ends & 35x19 shelf rails
- 18mm Melteca shelves
- Heavy duty castors

KERRI'S KOLOURS



Memphis Blue



Memphis Red



Memphis Green



Energise



Juicy



Caribbean



Olympia Yellow



Storm

BIRCHWOOD RANGE



Snowdrift



Raw Birch Ply

26 SINGLE SIDED BOOK/STORAGE UNIT



- 1200L x 300D x 1000H
- Industrial rubber wheeled castors
 - Adjustable Shelves

27 DOUBLE SIDED BOOK/STORAGE UNIT



- 1200L x 600D x 1000H
- Industrial rubber wheeled castors
 - Double Sided
 - Adjustable Shelves

82 SINGLE SIDED STORAGE UNIT



- A** 1200L x 680H x 300D
B 1200L x 980H x 300D
- Adjustable shelves
 - Plinth base

56 MOBILE STORAGE UNIT



- 1800L x 970H x 500D
- Suitable for blocks, maths equipment, books etc
 - Industrial rubber wheeled castors
 - Solid matching back

STANDARD COLOURS

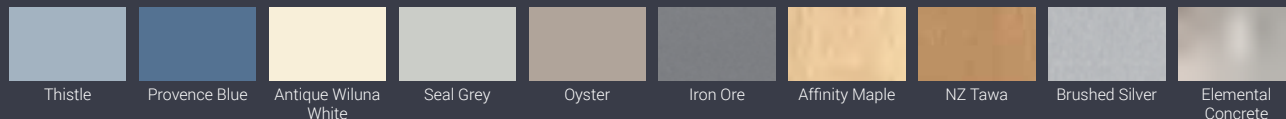

See inside back cover for more choices



Serpentine range

**link them, curve them,
change them, move them**

For the ultimate Innovative Learning Environment

The serpentine range has proved itself to be a great innovation for the innovative learning environments in today's early childhood centres, kindergartens and schools.

This gives you a range of pick and mix of different shelving and storage units that you can configure to meet your individual spaces and requirements. All units have solid matching backs so you can create your learning space with the units turned in the different ways to break up open spaces to make that all important reading, puzzle, playdough, art etc areas.

Mix these up with our shaped and linking tables, bean bags, fritters for the ultimate ILE space.



BIRCHWOOD RANGE

Early Childcare Centres & Kindergartens

Achieve your fresh and natural look with our new Melteca RAWBIRCH range. Team up with SNOWDRIFT and take advantage of using the hard wearing LPL Melteca that meets all Australian and New Zealand regulations for use in "public spaces".

Note that ALL furniture made by Mike's Woodshop can be made into these colours – including all tables, storage units and office furniture. Other woodgrain looks also available – see inside back cover for colour choices.



RAW BIRCH PLY

SNOW DRIFT

KERRI'S KOLOURS



Memphis Blue

Memphis Red

Memphis Green

Energise

Juicy

Caribbean

Olympia Yellow

Storm

BIRCHWOOD RANGE

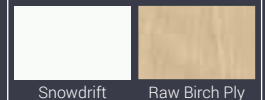

Snowdrift

Raw Birch Ply

77A CORNER UNIT



Pictured 800 x 800

800 x 800L x 420D x 690H
1200 x 1200L x 420D x 690H
• Fixed shelves

77B TRI UNIT



420L x 420D x 690H
• Fixed shelf

77C SHELVING UNIT



Pictured 1200L

1200L x 420D x 690H
800L x 420D x 690H (no division)
• Adjustable shelves

77E DRAWER UNIT



800L x 420D x 690H

77F ART & COLLAGE UNIT



900L x 420D x 690H
• Includes tote trays

77G CUBE CRATE UNIT



Pictured 1200L

1200L x 420D x 690H - 3 bins
800L x 420D x 690H - 2 bins
• Includes cube bins

77H CUPBOARD UNIT



800L x 420D x 690H
• 1 adjustable shelf

77J PAPER STORAGE UNIT



900L x 420D x 690H
• Fixed shelves to hold paper or big books

77K SLOPING SHELF UNIT

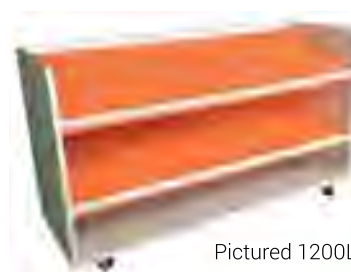

Pictured 1200L

1200L x 420D x 690H
800L x 420D x 690H
• 2 sloping & 1 flat shelf

77L TOTE TRAY UNIT



900L

900L x 420D x 690H - 3 rows trays
1200L x 420D x 690H - 4 rows trays
• Add your choice of large & small tote trays



1200L

77N CUBBY HOLE UNIT



1200L x 420D x 690H
• 4 long x 2 high cubby holes

STANDARD COLOURS

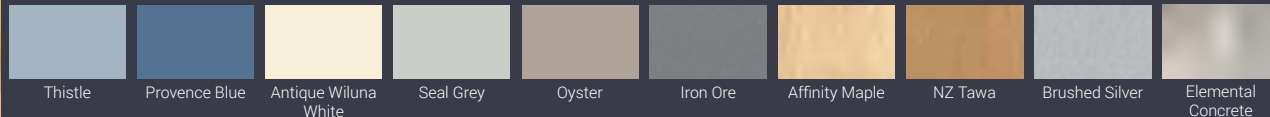

See inside back cover for more choices

44 SINGLE TOTE TROLLEY



600L x 570D x 710H

- Holds 12 small trays or 6 large trays
- Double sided
- Trays accessible both sides
- Twin wheel castors
- Trays additional

45 DOUBLE TOTE TROLLEY



980L x 570D x 710H

- Holds 24 small trays or 12 large trays
- Double sided
- Trays accessible both sides
- Twin wheel castors
- Trays additional

46 TRIPLE TOTE TROLLEY



1390L x 570D x 710H

- Holds 36 small trays or 18 large trays
- Double sided
- Trays accessible both sides
- Twin wheel castors
- Trays additional

136 DESK TRAY TROLLEY



960L x 600D x 1000H

- Holds 12 deep desk trays
- Single sided
- Industrial rubber wheeled castors
- Can be made to your specifications with deep or standard trays
- Trays additional

KERRI'S KOLOURS



Memphis Blue



Memphis Red



Memphis Green



Energise



Juicy



Caribbean



Olympia Yellow



Storm

BIRCHWOOD RANGE



Snowdrift

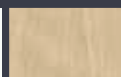

Raw Birch Ply

62 TOTE TRAY STORAGE 2 ROWS



- A** 900H x 600L x 400D - 16 Small Trays
- B** 1100H x 600L x 400D - 20 Small Trays
- Holds a combination of small and large trays
- Industrial rubber wheeled castors

47 TOTE TRAY STORAGE 3 ROWS



- A** 900H x 900L x 400D - 24 Small Trays
- B** 1100H x 900L x 400D - 30 Small Trays
- Holds a combination of small and large trays
- Industrial rubber wheeled castors

42 TOTE TRAYS

- Small 400 x 270 x 75
- Large 400 x 270 x 150
- Available in Grey, Red, Blue and Clear



NOTE

- All unit prices exclude tote trays & cube boxes
- Please choose your own combinations

48 TOTE TRAY STORAGE 4 ROWS



- A** 900H x 1200L x 400D - 32 Small Trays
- B** 1100H x 1200L x 400D - 40 Small Trays
- Holds a combination of small and large trays
- Industrial rubber wheeled castors

63 TOTE TRAY STORAGE 5 ROWS



- A** 900H x 1500L x 400D - 40 Small Trays
- B** 1100H x 1500L x 400D - 50 Small Trays
- Holds a combination of small and large trays
- Industrial rubber wheeled castors

STANDARD COLOURS

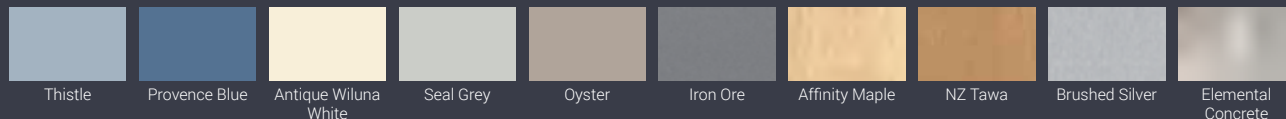

See inside back cover for more choices

41 MULTI STORAGE UNIT

A 1200L x 1100H x 400D

- Holds 20 small or 10 large tote trays or a combination of both
- Great storage for maths, reading, art equipment etc
- Design your own to suit your needs
- Industrial rubber wheeled castors

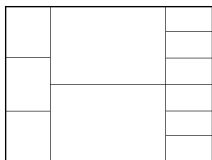

B 1200L x 900H x 400D

- Holds 4 large & 8 small tote trays

C 1200L x 700H x 400D

- Holds 3 large & 6 small tote trays



49 JUMBO MULTI STORAGE

1780L x 1100H x 400D

- Holds 20 small or 10 large trays or a combination of both
- Shelves for storage of games/puzzles etc
- Industrial rubber wheeled castors

NOTE

- All unit prices exclude tote trays & cube boxes
- Please choose your own combinations



51 9 CUBE STORAGE BOX



1200L x 1200H x 400D

- Holds 9 cube boxes
- Great in storage areas & resource rooms
- With or without the cube boxes
- Industrial rubber wheeled castors

52 12 CUBE STORAGE BOX



1600L x 1200H x 400D

- Holds 12 cube boxes
- Great in storage areas & resource rooms
- With or without the cube boxes
- Industrial rubber wheeled castors

KERRI'S KOLOURS



BIRCHWOOD RANGE

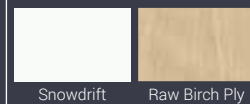

50 TOTE TRAY & CUBE BOX STORAGE



1650L x 1100H x 400D

- Storage shelves for games, puzzles, books etc
- Tote Tray storage
- Holds 3 large and 6 small tote trays
- Holds 4 cube boxes
- Great for classroom and resource rooms
- Industrial rubber wheeled castors

42 TOTE TRAYS



- Small 400 x 270 x 75
- Large 400 x 270 x 150
- Available in Grey, Red, Blue & Clear

43 CUBE BOXES

360L x 360W x 280H

- Available in:
 - Clear
 - Blue



53 CUBE MULTI STORE UNIT 1200



1200L x 1000H x 400D

- Holds 3 cube boxes
- Storage shelves for games, puzzles, books etc
- Great for classroom & resource rooms
- Industrial rubber wheeled castors

54 CUBE MULTI STORE UNIT 1600



1600L x 1000H x 400D

- Holds 4 cube boxes
- Storage shelves for games, puzzles, books etc
- Great for classroom & resource rooms
- Industrial rubber wheeled castors

NOTE

- All unit prices exclude tote trays & cube boxes
- Please choose your own combinations

STANDARD COLOURS

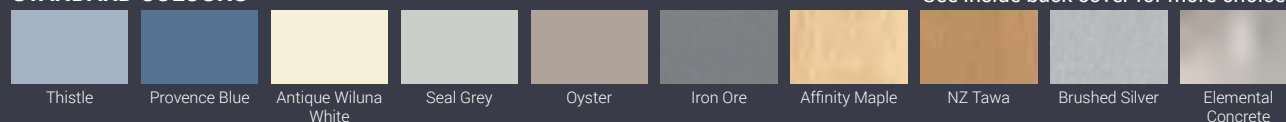

See inside back cover for more choices

59 CUBBY HOLES

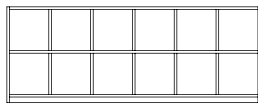

A - 1800L x 680H x 300D



B - 1500L x 680H x 300D

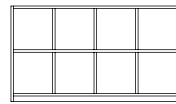

C - 1200L x 680H x 300D

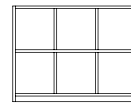

H - 900L x 680H x 300D

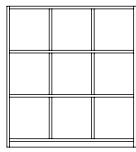

E - 900L x 980H x 300D

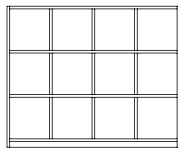

F - 1200L x 980H x 300D

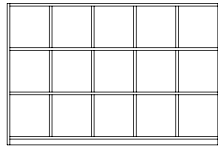

G - 1500L x 980H x 300D

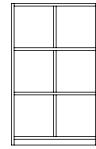

D - 600L x 980H x 300D



- All 300mm deep
- Average internal measurement 275W x 280H x 290D
- Plinth base
- Can be made to your specification

131 SHOE CUBBY HOLES

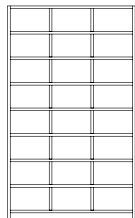

A - 24 holes
900L x 1500H x 300D

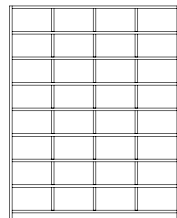

B - 32 holes
1200L x 1500H x 300D

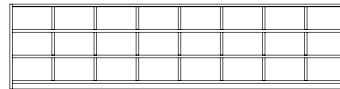

C - 24 holes
2400L x 600H x 300D

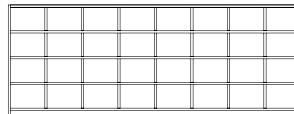

D - 32 holes
2400L x 800H x 300D



- Average internal measurement 275W x 160H x 290D
- 4 standard sizes available
- Plinth base
- Can be made to customer specifications

Options

- Melteca construction for indoor use
- White Ply construction for exterior use (suitable for covered deck or verandahs)

When using the White Ply outside, there are some basic rules to follow:

- Keep them in a covered area. So this means not where the direct rain can get them wet.
- Do not position these under roof lines that are not water tight to the space below.
- Do not position these to the outside of deck areas, where the rain can get them directly wet.
- If in the event that they do get wet, it is best if you dry them off
- Do not put them directly on the ground or grass.
- Do not water blast! Be careful when cleaning the decks around the cubby holes to ensure that they don't get an unexpected soaking.

KERRI'S KOLOURS



Memphis Blue



Memphis Red



Memphis Green



Energise



Juicy



Caribbean



Olympia Yellow



Storm

BIRCHWOOD RANGE



Snowdrift

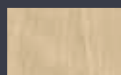

Raw Birch Ply

132 BAG CUBBY HOLES

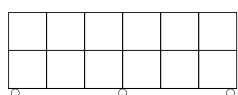

A - 2400L x 870H x 400D

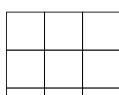

E - 1200L x 1270H x 400D

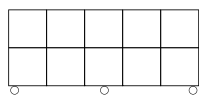

B - 2000L x 870H x 400D

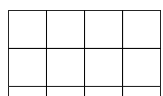

F - 1600L x 1270H x 400D

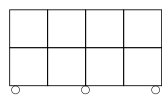

C - 1600L x 870H x 400D

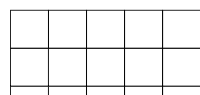

G - 2000L x 1270H x 400D



D - 800L x 1270H x 400D

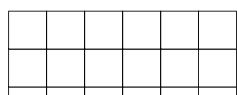

H - 2400L x 1270H x 400D

Average internal measurement 370W x 370H x 400D

- Industrial rubber wheeled castors
- Can be made to your specifications
- Will fit cube crates if required
- Can be made with plinth bases

Options

- Melteca construction for indoor use
- White Ply construction for exterior use (suitable for covered deck or verandahs)



A



E



F

133 BAG TROLLEY



A

- A** 1800L x 600D x 1300H - 30 aluminium hooks
- B** 1200L x 600D x 1300H - 18 aluminium hooks
- Double sided
- Industrial rubber wheeled castors

Options

- Melteca construction for indoor use
- White Ply construction for exterior use (suitable for covered deck or verandahs)

60 BAG TROLLEY



1300H x 1200L x 600D

- Double sided
- Total 18 hooks
- Tray on base for shoes
- Timber - Melteca construction for interior use
- Industrial rubber wheeled castors

STANDARD COLOURS

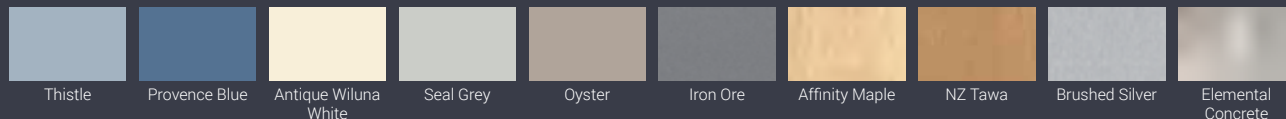

See inside back cover for more choices

31 ART TROLLEY



- 1050L x 600D x 700H
- Fits icecream containers in top
 - 3 shelves for paper storage
 - Industrial rubber wheeled castors
 - Solid matching back

32 PAPER STORAGE UNIT



- 1050L x 600D x 1000H
- Shelving for paper storage
 - Cutting table on top
 - Industrial rubber wheeled castors
 - Solid matching back

33 JUNIOR PAPER STORAGE



- 1050L x 600D x 700H
- Shelving for paper storage
 - Cutting table on top
 - Industrial rubber wheeled castors
 - Solid matching back

38 ART & COLLAGE TROLLEY



- 940L x 400D x 700H
- Fits icecream containers in top
 - 1 shelf for paper
 - Complete with 6 tote trays for storage
 - Industrial rubber wheeled castors
 - Solid matching back

KERRI'S KOLOURS



Memphis Blue

Memphis Red

Memphis Green

Energise

Juicy

Caribbean

Olympia Yellow

Storm

BIRCHWOOD RANGE

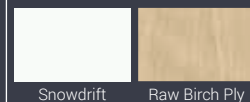

Snowdrift

Raw Birch Ply

40 DELUXE ART & COLLAGE TROLLEY



1200L x 600D x 700H

- Fits icecream containers in top
- 2 paper storage shelves
- 1 deep drawer
- Fits 4 small tote trays each side (total 8)
- Double sided
- Industrial rubber wheeled castors

387 DRYING UNIT



900L x 630D x 1000H

- 2 rows X 14 shelves (9mm MDF)
- Pull out shelves to put A2 art on to dry
- Cutting table on top
- Industrial rubber wheeled castors
- Solid matching back

23 PAPER PAMPHLET STORAGE



A 18 - 2 rows 500L x 300D x 1000H

B 27 - 3 rows 720L x 300D x 1000H

- Great to store coloured paper or stationery
- Fits A4 paper
- Removable shelves - 9 per row (10 gaps)
- Can be made to your specifications

135 PORTFOLIO STORAGE UNITS



A 30 - 2 rows 900L x 250D x 900H

B 45 - 3 rows 1135L x 250D x 900H

- 55mm gap between shelves
- To fit A4 clearfiles
- Can be made to your specifications

STANDARD COLOURS

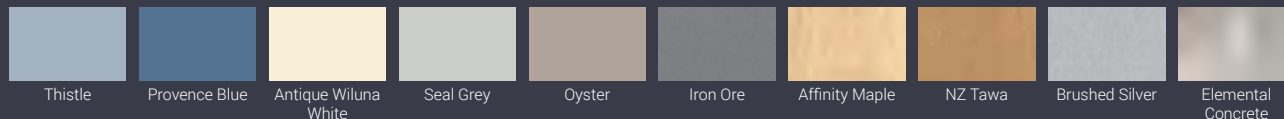

See inside back cover for more choices

58 TEACHERS STORAGE CUPBOARD



- A** 1200L x 1200H x 400D - Adjustable shelves
B 1200L x 1800H x 400D - 1 fixed & 2 adjustable shelves
- 18mm Melteca construction
 - Locks available

314 1800 CUPBOARD



- 1800H x 800W x 400D
- 1 fixed and 2 adjustable shelves (4 cavities)
 - 18mm Melteca construction
 - Locks available

381 CUBEBOX/TOTE TRAY SHELVING

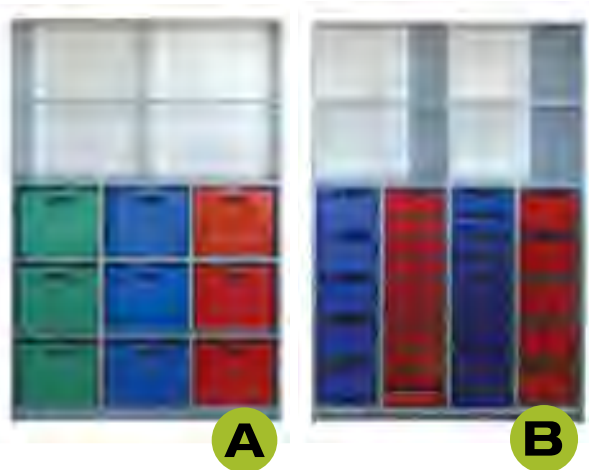

- 1800H x 1200W x 400D
- A** Holds 9 cube crates
B Holds 4 rows of tote trays
- Adjustable shelves
 - Plinth base
 - Cubes not included
 - Tote trays not included - select sizes & quantity to suit

451 SICK BAY (SINGLE) BED



- 2000L x 750D x 450H
 Mattress 1900 x 750
- 38mm round ends
 - 50 x 25mmn rectangular tube frame
 - MDF base
- Options - Foam Mattress
- with cotton covering
 - with vinyl covering

KERRI'S KOLOURS



BIRCHWOOD RANGE

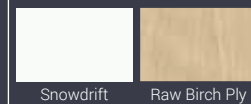



TABLES & DESKS

CONTENTS

Tables	37-38
Jellybean Table	39
Horse Shoe Tables.....	40
Tall Tables	41
Swerve Tables	42
Omega Tables.....	43
Switch Tables	44
Sigma Tables.....	45
'O's and Bow Tables	46
Gamma & Delta Tables.....	47
Alpha Tables.....	48
Shaped Tables	49
Study Carrels.....	50
School Desks.....	51-52
Computer Tables	53
Technology Tables	54
Teachers Desks	55
Folding Tables & Trolleys	56

85 CLASSROOM TABLES



Sizes Available

- 800 x 800 800 x 600
- 1200 x 800 1200 x 600
- 1600 x 800 1600 x 600
- 1800 x 800 1800 x 600

• Other sizes available on request

Optional Extras

- Whiteboard tops
- Adjustable legs
- 530 - 625 - 685 - 725mm
- Tall Tables 800 & 900 high
- With 4 locking castors
- Heavy duty frame with 51mm round legs

86 TOTE TRAY TABLES



- 1800 x 800 - 6 trays
- 1200 x 800 - 4 trays
- 1600 x 800 - 4 trays
- Option for deep or standard desk trays

Optional Extras

- Whiteboard tops
- Adjustable legs
- 530 - 625 - 685 - 725mm
- With 4 locking castors

**Refresh your existing furniture
Replacement table tops available**

KERRI'S KOLOURS



BIRCHWOOD RANGE

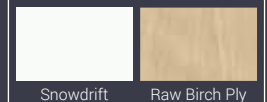

87 ROUND TABLES



900 Diameter
1200 Diameter

Optional Extras

- Whiteboard tops
- Adjustable legs - 530 - 625 - 685 - 725mm
- With 4 locking castors

90 TRAP TABLES

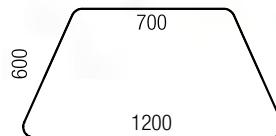

1200L x 600

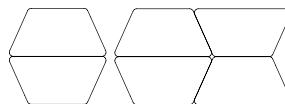

Optional Extras

- Whiteboard tops
- Adjustable legs - 530 - 625 - 685 - 725mm
- Tall Tables 800 & 900 high
- With 4 locking castors
- Heavy duty frame with 51mm round legs

89 KNEELER TABLES



1200 x 400 x 400H
1200 x 600 x 400H

- All tables can be made at kneeler heights

Optional Extras

- Whiteboard tops

91 TWO TIERED TABLES



1200 x 600 x 725H

- Shelf at 350mm high

Standard Table Heights

• Pre-School	500mm	• Kneelers	400mm
• Year 1-2	530mm	• Year 1-2	560mm (Desk)
• Year 3-4	625mm	• Year 1-3	800mm (Tall Table)
• Year 5-6	685mm	• Year 4-13	900mm (Tall Table)
• Year 7-8	725mm		

Table Specifications

- 18mm Melteca tops
- Solid 2mm PVC edges
- Rounded corners
- 32mm round steel legs

STANDARD COLOURS

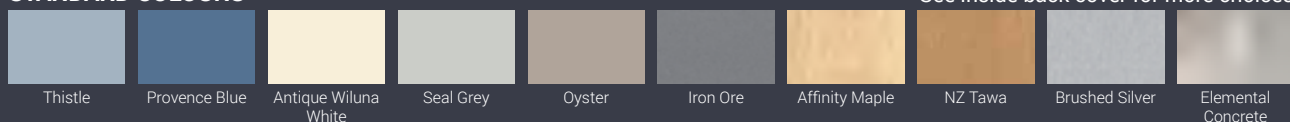

See inside back cover for more choices



- Optional Extras**
- Whiteboard tops
 - Adjustable legs
 - 530 - 625 - 685 - 725mm
 - With 4 locking castors

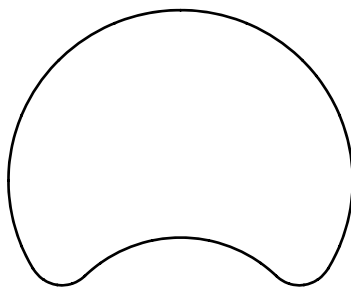

- 1500 x 1200 x height required
- 18mm Melteca tops
 - Solid 2mm PVC edges
 - 32mm round steel legs

A great addition to an ILE! This table is an alternative to a horse shoe table where the principal idea is the same except you have a deeper work space.

- Standard Table Heights**
- **Kneelers** 400mm high
 - **Pre-School** 500mm high
 - **Year 1-2** 530mm high
 - **Year 3-4** 625mm high
 - **Year 5-6** 685mm high
 - **Year 7-8** 725mm high

KERRI'S KOLOURS



BIRCHWOOD RANGE

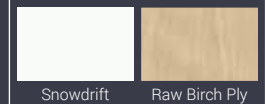



Optional Extras

- Whiteboard tops
- Adjustable legs
- 530 - 625 - 685 - 725mm
- With 4 locking castors



A must for every Innovative Learning Environment. These are great for working with small groups of children within the classroom learning spaces. Is popular to have a whiteboard top on the horseshoe table. We also like to be looking at the teachers sitting position and we mostly supply the teacher a gas lift chair that supports and looks after their backs and well-being. This means that in the year 1 -4 rooms, we like to recommend using the 625h table with the 400h MLE stools, Move 'n' Rock stools or Cube stools. This means the children are sitting at a slightly higher seat, but the teacher is also comfortable. Is a "happy medium". This replaces the traditional teacher's desk and team it up with a Teachers work podium and this becomes a practical teaching space for the children and teachers.

1800 x 1200 x height required

- 18mm Melteca tops
- Solid 2mm PVC edges
- 32mm round steel legs

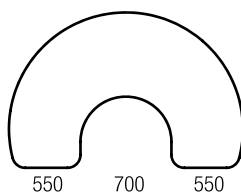

Standard Table Heights

- **Kneelers** 400mm high
- **Pre-School** 500mm high
- **Year 1-2** 530mm high
- **Year 3-4** 625mm high
- **Year 5-6** 685mm high
- **Year 7-8** 725mm high

STANDARD COLOURS

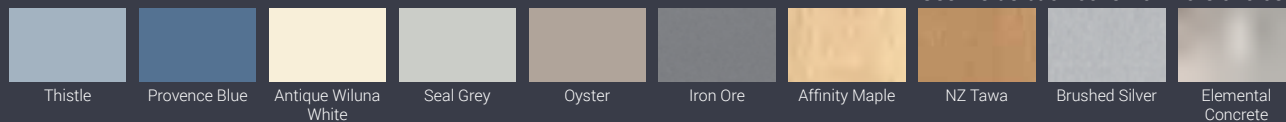

See inside back cover for more choices

Optional Extras
 • Whiteboard tops



Heights
 800H - Year 1-4
 900H - Year 4-13

Tall tables are a very firm favourite with the children in an Innovative Learning Environment. The children sit, perch or lean on the tables and these are great for children working in small groups and for all collaborative learning.

- 18mm Melteca tops
- Frame with heavy duty rails and 51mm round legs
- Any table shape can be made into a "Tall" table

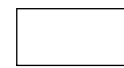

1200 x 600
 1600 x 600
 1800 x 600

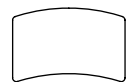

Swerve Top
 1200 x 800

1200 x 800
 1600 x 800
 1800 x 800



Sigma Top
 1200 x 730

1200 x 1200
 1200 x 1800
 1200 x 2400

KERRI'S KOLOURS



Memphis Blue

Memphis Red

Memphis Green

Energise

Juicy

Caribbean

Olympia Yellow

Storm

BIRCHWOOD RANGE

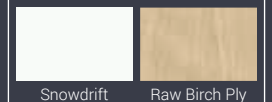

Snowdrift

Raw Birch Ply

Optional Extras

- Whiteboard tops
- Adjustable legs
- 530 - 625 - 685 - 725mm
- Tall Tables 800 & 900 high
- With 4 locking castors
- Heavy duty frame with 51mm round legs



1200 x 800 x Height required

- 18mm Melteca tops
- Solid 2mm PVC Edges
- 32mm round steel legs

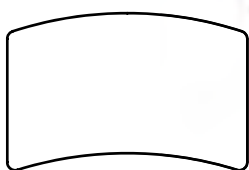

1200 x 800

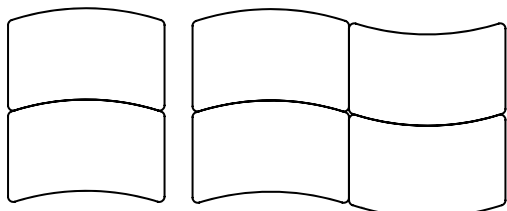

The swerve table enables 2 children to sit side by side on each side of the table. Replaces the traditional group table within the classroom area but with the flexibility of putting them together for bigger groups and as a single table for smaller numbers. This table has been most popular as a tall table.

STANDARD COLOURS

See inside back cover for more choices

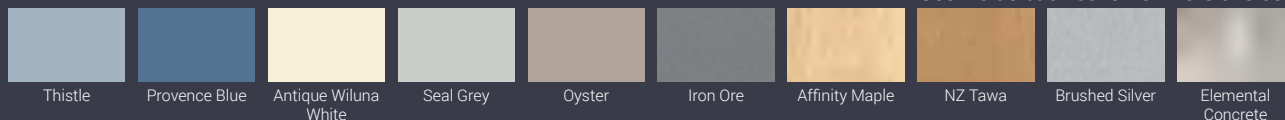

Thistle

Provence Blue

Antique Wiluna
White

Seal Grey

Oyster

Iron Ore

Affinity Maple

NZ Tawa

Brushed Silver

Elemental
Concrete

Optional Extras

- Whiteboard tops
- Adjustable legs
 - 530 - 625 - 685 - 725mm
- With 4 locking castors



- 18mm Melteca tops
- Solid 2mm PVC Edges
- 32mm round steel legs



The Omega tables are a very popular option for an Innovative Learning Environment and it gives flexibility to change the shape to suit different tasks during the day. Now with the new Connecta table, you can also make up conference style seating. The Connecta table teamed up with a set of Omega tables gives you flexibility in the classroom and also gives you back the "group stand-alone table"

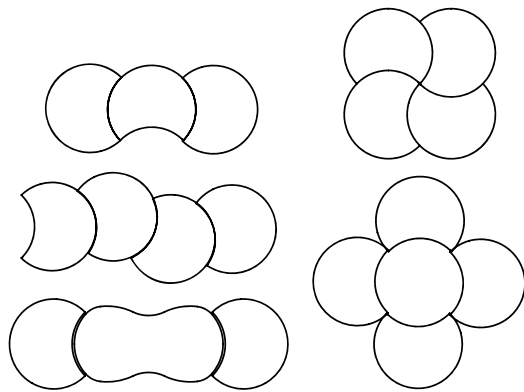

Year 1-6

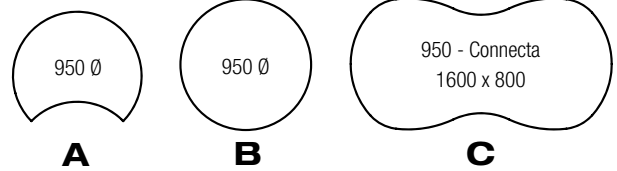

Year 7-13

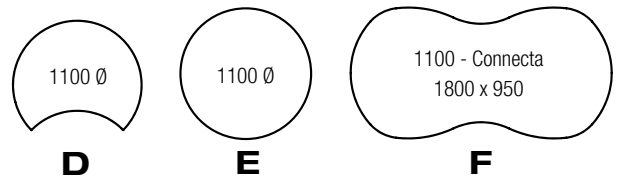

KERRI'S KOLOURS



BIRCHWOOD RANGE

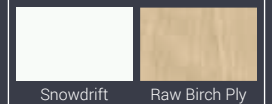

Optional Extras

- Whiteboard tops
- Adjustable legs
- 530 - 625 - 685 - 725mm
- With 4 locking castors



- 18mm Melteca tops
- Solid 2mm PVC Edges
- 32mm round steel legs



Switch tables says it all. Switch them, change them, move them. These tables give you the more traditional classroom table with the curves giving them a more modern look. These tables are great using in groups of 2, 3, 4 & 6 tables. Two tables gives you the "group stand-alone table" but with the flexibility of joining them together with more tables or using these as a smaller stand-alone table. A great addition to an Innovative Learning Environment.

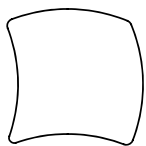

A - 800 x 800 Year 1-6
B - 1000 x 1000 Year 7+

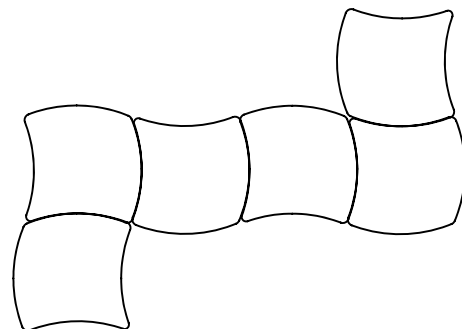
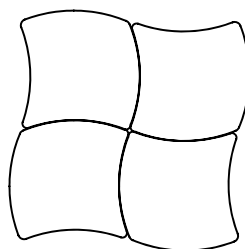

Standard Table Heights

- Kneelers 400mm high
- Pre-School 500mm high
- Year 1-2 530mm high
- Year 3-4 625mm high
- Year 5-6 685mm high
- Year 7-8 725mm high

STANDARD COLOURS

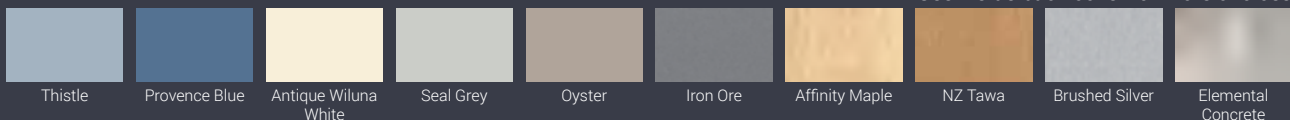

See inside back cover for more choices



- Optional Extras**
- Whiteboard tops
 - Adjustable legs
 - 530 - 625 - 685 - 725mm
 - Tall Tables 800 & 900 high
 - With 4 locking castors
 - Heavy duty frame with 51mm round legs

- 18mm Melteca tops
- Solid 2mm PVC Edges
- 32mm round steel legs

Another great table system for the Innovative Learning Environment. These tables work very well in a bigger open space where they can be moved and changed depending on the day and what is happening within the learning space. These can be set up in a circle or semi-circle for conferencing and also snaked around the room. You would allow 3 children per table when setting up your class numbers.

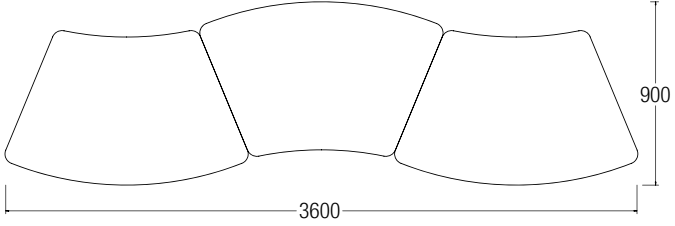
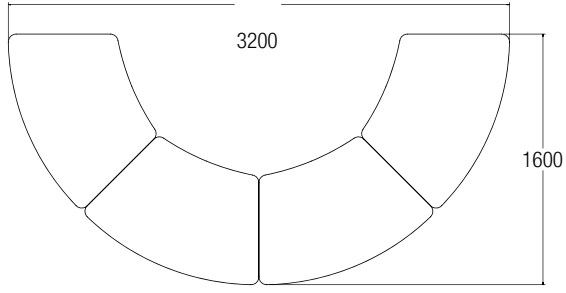
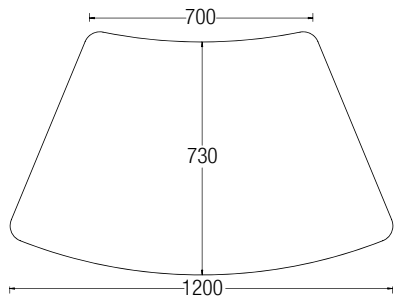

KERRI'S KOLOURS



BIRCHWOOD RANGE

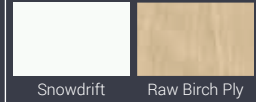

100 'O'S AND BOW TABLES



Optional Extras

- Whiteboard tops
- Adjustable legs
- 530 - 625 - 685 - 725mm
- With 4 locking castors

100 'O' TABLE

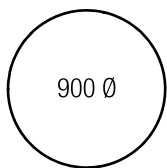

100B CURVED BOW

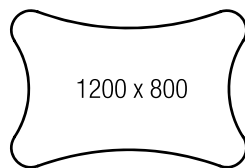

100C STRAIGHT BOW

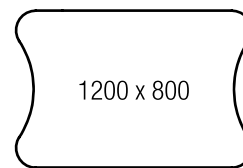

These are a flexible group of tables that work very well as individual tables and also joining them together to form bigger groups. Connecting them around into an arc gives you great conferencing style teaching opportunities.

Standard Table Heights

- Kneelers 400mm high
- Pre-School 500mm high
- Year 1-2 530mm high
- Year 3-4 625mm high
- Year 5-6 685mm high
- Year 7-8 725mm high

- 18mm Melteca tops
- Solid 2mm PVC Edges
- 32mm round steel legs

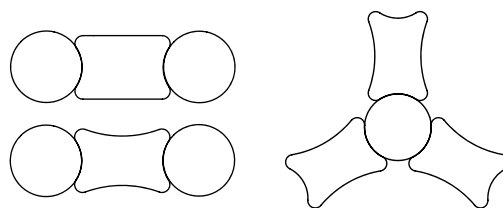

STANDARD COLOURS

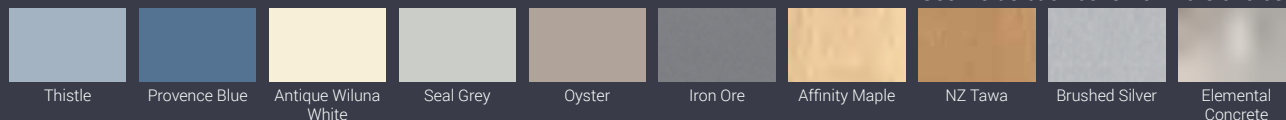

See inside back cover for more choices

165 - 166 - 167 GAMMA & DELTA TABLES



Optional Extras

- Whiteboard tops



Gamma & Delta Table Specifications

- 18mm Melteca tops
- Solid 2mm PVC edges
- All tables have rounded corners
- 51mm round steel legs

165 GAMMA LEFT TABLE

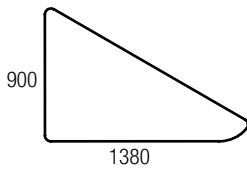

166 GAMMA RIGHT TABLE



167 DELTA TABLE

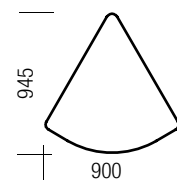

The Gamma and Delta range of tables are a flexible, multi-functional range with many uses and configurations.

Ideal in the Innovative Learning Environment where they can be changed quickly into different configurations.

This range comes standard with heavy duty frames and 51mm round legs.

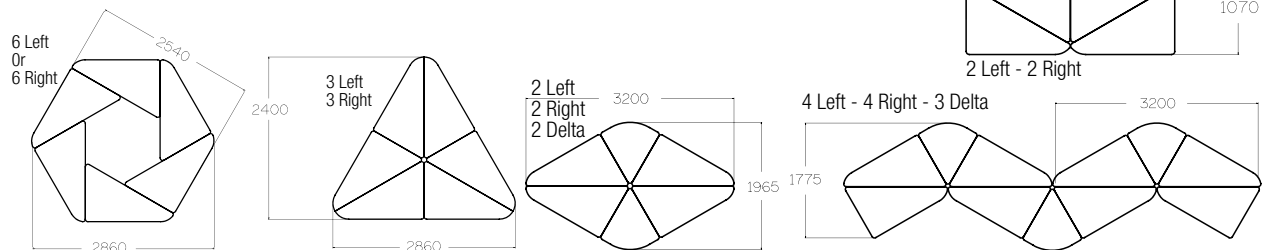

KERRI'S KOLOURS



BIRCHWOOD RANGE

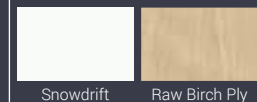

Optional Extras

- Whiteboard tops
- 1 Adjustable legs - 530 - 625 - 685 - 725mm
- 1 With locking castors



A



B

Table Specifications

- 18mm Melteca tops
- Solid 2mm PVC edges
- 32mm round steel legs

A - Alpha 3

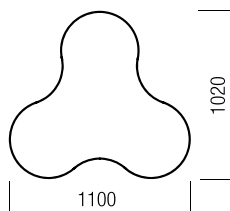

B - Alpha 4

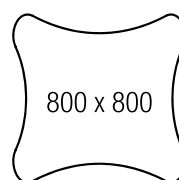

The Alpha table is a smaller table for children working in small groups. Are great as a Kneeler and teamed up with our Fritters.

STANDARD COLOURS

See inside back cover for more choices

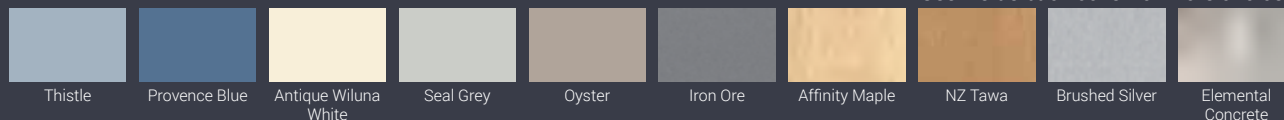

TABLES & DESKS

92 STARFISH

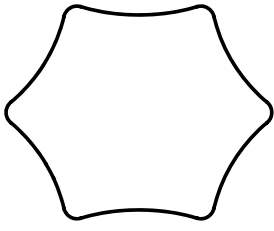

1500 x 1200

93 JELLYFISH

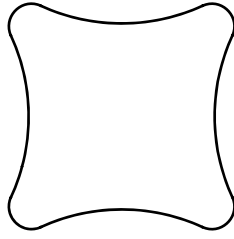

1200 x 1200

94 LIMPET

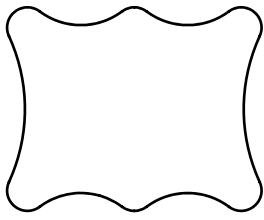

1500 x 1200

96 SCALLOP

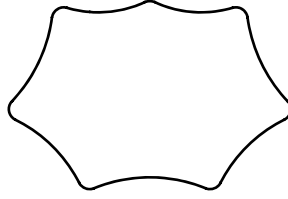

1800 x 1200

97 OCTOPUS

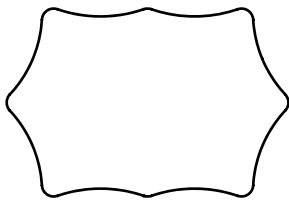

1800 x 1200

98 HEXAGON

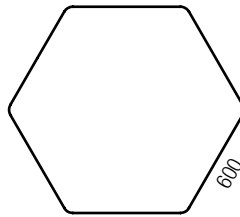

1200 x 1200

99 OCTAGON

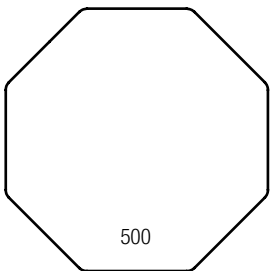

1200 x 1200

101 SEMI CIRCLE

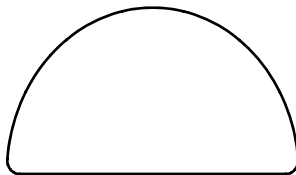

1200 x 600

Optional Extras

- Whiteboard tops
- Adjustable legs
- 530 - 625 - 685 - 725mm
- With 4 locking castors

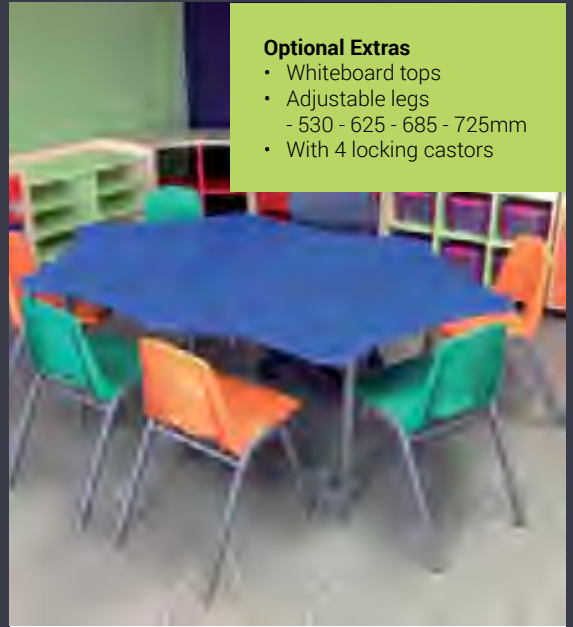

All Table Specifications

- 18mm Melteca tops
- Solid 2mm PVC edges
- All tables have rounded corners
- 32mm round steel legs

Shaped Tables

KERRI'S KOLOURS



BIRCHWOOD RANGE

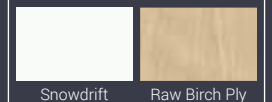



Single:
800W x 600D x 400H sides



Double
1600W x 600D x 400H sides

The study carrel's have come full circle and are back in the classrooms. When you have a large open Innovative Learning Environment, there are always children who like working on their own with no interruptions. It is always a great option to have a couple of these within these big working spaces.

Specifications

- 18mm Melteca tops
- Solid 2mm PVC edges
- Rounded corners
- 32mm round steel legs
- 200mm shelf
- Choose your desk height

Standard Table Heights

• Pre-School 500mm	• Year 5-6 685mm	• Year 1-2 560mm (Desk)
• Year 1-2 530mm	• Year 7-8 725mm	• Year 1-3 800mm (Tall Table)
• Year 3-4 625mm	• Kneelers 400mm	• Year 4-13 900mm (Tall Table)

STANDARD COLOURS

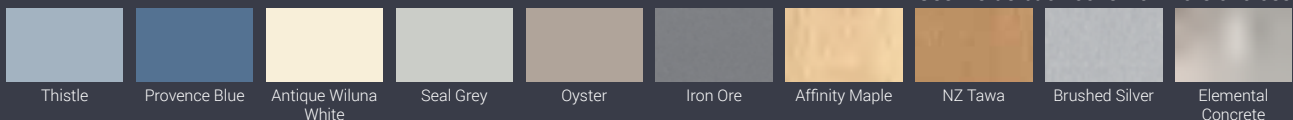

See inside back cover for more choices

102 LIFT TOP DESK



Top 600 x 500

- Comes complete with desk tray
- Frame is 32mm round legs
- Straight legs so desks can form groups
- Front corners rounded
- Heavy duty steel hinge with steel pivot
- Option for deep or standard desk trays

103 WOODEN PEN RAIL DESK



Top 600 x 500

- Solid wooden construction (hardwood)
- Comes complete with desk tray
- Frame is 32mm round legs
- Straight legs so desks can form groups
- Heavy duty steel hinge with steel pivot
- Option for deep or standard desk trays
- Instock for immediate dispatch

160 MODESTY PANEL



Add a modesty panel to the lift top, contour, fixed top or single desks.

123 DESK TRAYS



A Standard 400D x 520W x 80H
B Deep 400D x 520W x 120H

Standard Desk Heights

- Year 1-2 560mm high
- Year 3-4 625mm high
- Year 5-6 685mm high
- Year 7-8 725mm high

REMEMBER TO CHOOSE THE DEEP OR STANDARD DESK TRAYS

KERRI'S KOLOURS



BIRCHWOOD RANGE

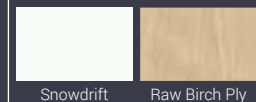

104 CONTOUR DESK



600 x 500 fixed top

- Comes with or without desk tray
- Frame is 32mm round legs
- Straight legs so desks can form groups
- Rounded corners
- Option for deep or standard desk trays

105 FIXED TOP DESK



600 x 475 fixed top

- Comes with or without desk trays
- Frame is 32mm round legs
- Straight legs so desks can form groups
- Rounded corners
- Option for deep or standard desk trays

318 SINGLE DESK



600 x 475 fixed top

- Comes with or without desk tray
- Straight legs (desks can form groups)
- Round corners at front, square corners on back
- Option for deep or standard desk trays

319 DOUBLE DESK



1200 x 600 fixed top

- Comes with or without desk trays
- Straight legs (desks can form groups)
- Round corners at front, square corners on back
- Option for deep or standard desk trays

STANDARD COLOURS

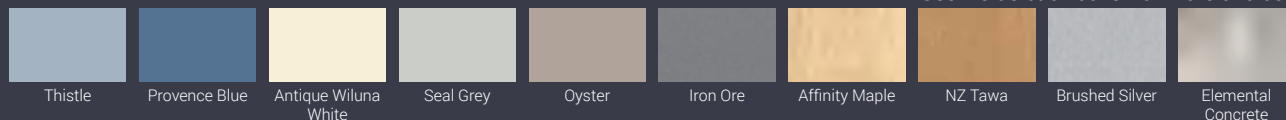

Thistle

Provence Blue

Antique Wiluna
White

Seal Grey

Oyster

Iron Ore

Affinity Maple

NZ Tawa

Brushed Silver

Elemental
Concrete

See inside back cover for more choices

399 COMPUTER iQuads



- Lengths 1200 - 1 computer
1800 - 2 computers
2400 - 3 computers
- Frame 50x50mm square legs
50x25mm heavy duty rails
- 25mm tops with square corners
- Option to add castors
- Heights 530 - 625 - 685 - 725
- Can be made to size

Sizes
1200 x 600
1800 x 600
2400 x 600

Option
• Add cable ports

277 LAPTOP TROLLEY



- 600 x 600 shaped top
- Mobile

Options:
• Adjustable Height
• Fixed Height 725mm

395 COMPUTER TABLES



Sizes
800 x 600
1200 x 600
1800 x 600
2400 x 600

Lengths
800 - 1 computer
1200 - 1 computer
1800 - 2 computers
2400 - 3 computers

Heights
530 - 625 - 685 - 725 - 800 - 900

- Tops - 18mm Melteca
Frames - 51mm ø legs with heavy
50x25 rails
- Round or square corners
 - Option to add castors
 - Option to add cable ports
 - Can be made to size

KERRI'S KOLOURS



Memphis Blue

Memphis Red

Memphis Green

Energise

Juicy

Caribbean

Olympia Yellow

Storm

BIRCHWOOD RANGE

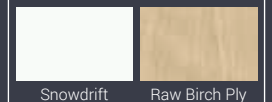

Snowdrift

Raw Birch Ply

129 LAB BENCHES



- 1200L x 600W x 900H
1800L x 600W x 900H
- 35mm x 19mm rectangular rails
 - 32mm square frame
 - 30mm HPL Formica tops - long sides with rolled edges & flat clash on ends

390 TECHNOLOGY HEAVY DUTY TABLES



- | | |
|--------------|---------------|
| 1200L x 600W | 1200L x 1200W |
| 1800L x 600W | 1200L x 1800W |
| 1200L x 800W | 1200L x 2400W |
| 1800L x 800W | |
- Heights 530 - 625 - 685 - 725 - 800 - 900
- 51mm round legs/heavy duty rail
 - Can be made to size
 - HPL laminate table tops are best used in Food Tech, Science & Art Rooms
 - 30mm HPL Formica tops - long sides with rolled edges & flat clash on ends

389 HEAVY DUTY TABLES WITH SHELF



- 1800L x 600W x 900H
1200L x 600W x 900H
- 51mm round legs/heavy duty rails
 - Can be made to size
 - 30mm HPL Formica tops - long sides with rolled edges & flat clash on ends

FORMICA COLOURS

You can choose any of the colours from the Laminex HPL or Formica ranges. These colours are some of the more popular colours for Education

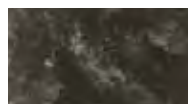

Flinders Blue



Flint Crystal



Blue Quartz



Arctic Stone



Ironstone



Soft Maple



Memphis Blue



Memphis Red



Memphis Green



Energise

338 TEACHERS DESK - 1200

1200 x 700

- 2 drawers complete with steel drawers and runners
- Melteca colours

**HEAVY DUTY DESK
BUILT TO LAST**



339 TEACHERS DESK - 1500

1500 x 750

- 1 deep drawer and 2 standard drawers complete with steel drawers and runners
- Melteca Colours

**HEAVY DUTY DESK
BUILT TO LAST**



322 TEACHERS DESK - 1500

1500 x 750

- 1 deep drawer and 2 standard drawers complete with steel drawers and runners
- Melteca Colours
- 100mm upstand around back

**HEAVY DUTY DESK
BUILT TO LAST**



See Office Furniture for other designs & styles

KERRI'S KOLOURS



Memphis Blue

Memphis Red

Memphis Green

Energise

Juicy

Caribbean

Olympia Yellow

Storm

BIRCHWOOD RANGE

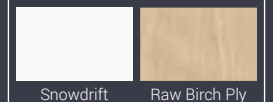

Snowdrift

Raw Birch Ply

928 LIFE STANDARD FOLDING TABLE

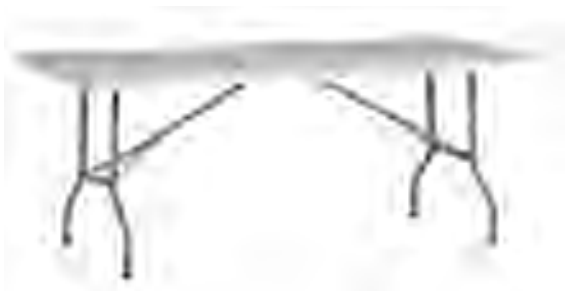

1200 x 770mm
 1830 x 770mm
 2428 x 760mm
 2438 x 760mm -2-piece top that folds in half

- Heavy duty 45mm white polypropylene top
- 25-28mm tubular steel legs to make tables easy to fold away, move and store
- Waterproof
- UV resistant
- Easy to clean

929 LIFE ROUND FOLDING TABLE



1200mm diameter
 1500mm diameter
 1800mm diameter

- Heavy duty 45mm white polypropylene top
- 25-28mm tubular steel legs to make tables easy to fold away, move and store
- Waterproof
- UV resistant
- Easy to clean

938 ROUND FOLDING TABLE TROLLEY



Fits 10 - 1800mm ø tables

1900mm long x 1200mm wide x 1200mm high
 (1325mm high inc castors)

- 18mm MDF Top with strips of carpet glued to help reduce fatigue to table tops
- Standard 32mm square powder coated frame with heavy duty braked castors
- This trolley can be made to fit other sized tables

937 STANDARD FOLDING TABLE TROLLEY



Fits 10 - 1800mm to 2400mm long tables

1600mm long x 700mm wide x 700mm high
 (825mm high inc castors)

- 18mm MDF Top with strips of carpet glued to help reduce fatigue to table tops
- Standard 32mm square powder coated frame with heavy duty braked castors

STANDARD COLOURS

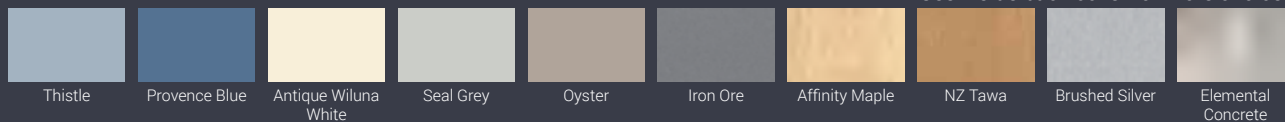

Thistle

Provence Blue

Antique Wiluna
White

Seal Grey

Oyster

Iron Ore

Affinity Maple

NZ Tawa

Brushed Silver

Elemental
Concrete

See inside back cover for more choices





SEATING

CONTENTS

Summit Chairs.....	59-60
Rainbow Chairs	61
Titan Chairs	62
Stools.....	63-65
Cafe Stools & Chairs	66-68
Linking Chairs	69
Guest Chairs.....	70-76
Office Chairs.....	77-80
Office Stools	80-81
Chair Mats.....	81
Footrests	81

We welcome to our range of Summit Chairs

This chair is a multi-functional chair that is available as a chair, a gas lift & an architectural gas lift. The seats have a comfortable flexible back which offers our children the "wriggle" feature that is so important in the ILE environment. Complete with a 25mm x 1.6mm heavy duty steel frame this makes this chair a leading contender for our ILE in New Zealand Schools.

This chair comes with 3 different size seat shells which include:

Sizes	Heights	Seat size	Overall width
Year 1-2	310mm	340w x 320d x 320h (Small)	395mm
Year 3-4	360mm	400w x 400d x 390h (Medium)	450mm
Year 5-6	400mm	400w x 400d x 390h (Medium)	450mm
Year 7-13	450mm	440w x 415d x 420h (Large)	490mm

This year 3-6 size chair has a more generous seat size to suit our diverse population of children whom seem to be getting bigger with each generation.



310mm

360mm

400mm

450mm

450mm

COLOURS

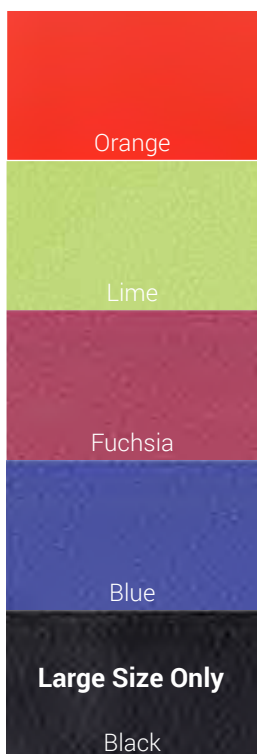

180D SUMMIT CHAIR WITH TABLET ARM

**Shell size**

Medium
Large

- Add a tablet arm to the Summit Chair
- Can fit on the 360, 400 & 450 chairs
- Flips up for ease of sitting down & standing up

All chairs are available in the 4 colours and we have also added Black into the Senior chair range

180B STANDARD GAS LIFT CHAIRS

**Shell size Height ranges**

Medium 430 - 550mm
Large 430 - 550mm

All chairs are available in the 4 colours and we have also added Black into the Senior chair range.

180C ARCHITECTURAL GAS LIFT CHAIRS

**Shell size Height ranges**

Medium 600 - 850mm
Large 600 - 850mm

All chairs are available in the 4 colours and we have also added Black into the Senior chair range.

Summit Gas lift & tablet arm chairs

This gas lift chair has the advantage of being supplied in both the medium and large size seat as a primary school size along with an adult size shell for our year 7-13's.

rainbow chairs

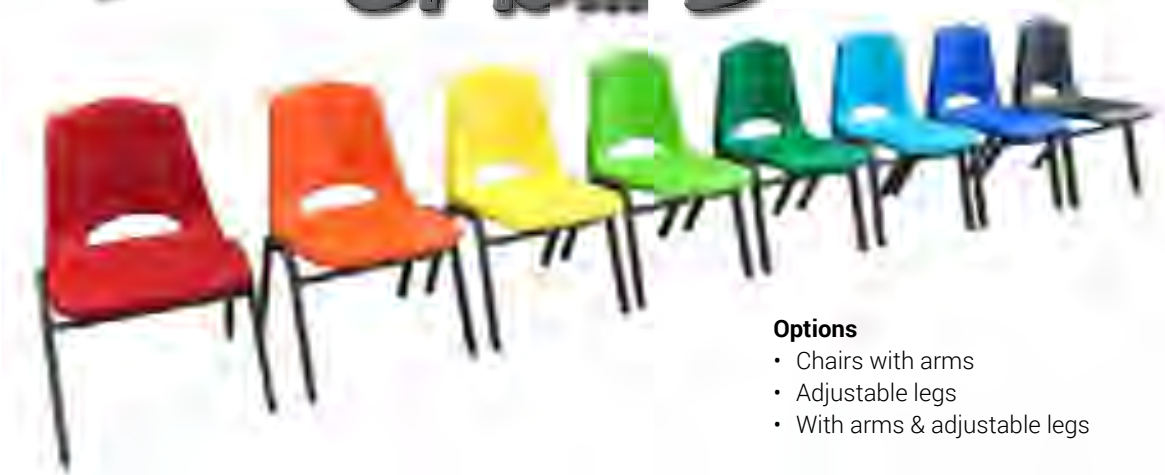

Options

- Chairs with arms
- Adjustable legs
- With arms & adjustable legs

Our Rainbow range is an excellent, well priced chair for preschool and primary schools. They come in a range of 8 colours that are colour co-ordinated with the Melteca colours, so that you can match the table and chair colours together. So you can create a multi coloured space using a range of table top colours and chairs, create a colour co-ordinated areas & groups with the "red" tables and chairs here and the "blue" over there, contrast the chairs with the tables and as we have also added the storm colour, you can create an industrial look with the silvers or wood grain look on the tables and the charcoal chairs.



Sizes & Heights

310mm high	Preschool	H600	W380	D450
310mm high	with arms	H600	W410	D450
310mm high	Year 1 & 2	H600	W380	D450
360mm high	Year 3 & 4	H645	W380	D470
Seat size (actual)		H320	W350	D320

Specifications

- Polypropylene Seat
- Heavy duty 35x16mm flat oval tube frame finished with a grey hammertone powder coat finish.
- The arm chair frame is 25mm round tube frame finished with a grey hammertone powder coat finish.
- Stackable
- 8 Colours – Lemon, Green, Juicy, Red, Energise, Carribean, Blue & Storm.

CHOOSE YOUR COLOUR





Specifications

- 15 year warranty
- Complies with the latest European standards relating to ergonomics- EN1729
- Made from virgin polypropylene
- 3 colour options
- 160kg weight rating (size 6 chair)
- Can be stacked up to 12 high
- 5 sizes available
- Generally available ex stock

Sizes

- Size 2 – 310h Preschool
- Size 3 – 350h Year 1-2
- Size 4 – 380h Year 3-4
- Size 5 – 430h Year 5-6
- Size 6 – 460h Year 7-13 (adult size)

STOCK COLORS



INDENT COLORS
(APPROX 10-12 WEEK DELIVERY)



126 MLE STOOL



PACIFICA VINYL



400H - Year 1-6
 450H - Year 7-13
 550H - Year 1-4
 660H - Year 4-13

- 19mm square steel frame
- 45mm foam seat

300 MOVE 'N' ROCK STOOLS



305H - Preschool, Year 1-2
 380H - Year 3-6

- Top diameter 320mm
- Base diameter 330mm
- Combine high student energy and the need to focus with this vibrantly coloured, motion seating solution
- Allows rocking and tilting motion in all directions with a unique rounded base design
- Stool shell is formed from durable polypropylene
- Bottom rubber padding is securely screwed to the stool body
- Slightly recessed seat is filled with soft rubber for comfort
- Lightweight and easy to transport
- Choose from 4 high style colours and 2 seat heights

124 PEPPER STOOL

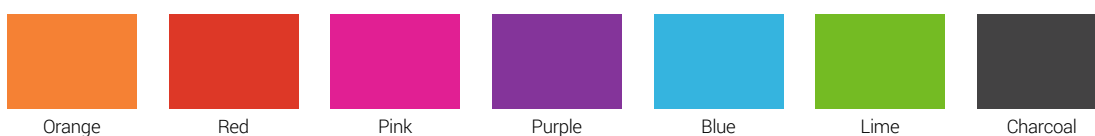

A great addition to our Innovative Learning Environment Range
 450H - Year 7-13
 550H - Year 1-4
 660H - Year 4-13

- 25mm round solid-welded steel frame
- Polypropylene contoured seat with comfy curved back
- Will stack 4 high
- 7 colours

301 JARI STOOL

**Fabric:**

Has a very high Martingale rub test, good stretch and low fire rating, as well as being:

- Anti-bacterial
- Waterproof
- Mould-proof

The seats can easily be removed and re-upholstered/replaced if necessary

Warranty:

10 years, covering faulty workmanship and parts. It doesn't cover wear and tear, abuse and inappropriate use of the product.

Height:

Adjustable 400mm – 500mm

Colours:

Blue, red, yellow and white/lime seat

- Tested to 130kg
- Each stool comes in a box, fully assembled

116 ICON SUPER CHAIR



Adult Size Only 450h - Year 7+
79005h x 400w x 540d • Seat 450h

- U.V. Stabilised
- Stack Vertically
- Ventilation holes
- Heavy duty chair
- Maintenance free
- 1 year warranty

Navy

925 BENCH SEAT



2000L x 250W x 400H

- All aluminium construction
- 45mm round aluminium legs
- Stackable

671 BURO REVO STOOL



555h x 540w x 500d
Seat 490-675h • Diameter 350mm

- Adjustable seat height
- High density polyurethane moulded foam
- 120kg / 4-5 hours



Black

Vinyl

516 SPIN STOOL



390 diameter top
420mm - 550mm gas lift

- 50mm upholstered seat
- Ring under seat means seat height can be altered easily
- Fabric coverings in Breathe. See page 70 for colour choices

397 CAFE STOOL



550H
660H
740H

- 400mm diameter seat
- 25mm heavy duty frame
- Available in Quantum or vinyl fabrics
- Can also choose any fabric from our range

252 FLY CHAIR



A 4 Legs
B Sled base

- Seat Height 450h
- 100% polypropylene
- Strong 16mmx2mm gauge tubular frame
- Powder coated black frame
- Stackable

Weight Rating:

4 legs - 130kg
Sled - 150kg

Sitting Hours:

Konfurb indicative 3-4 daily

5 year guarantee

Colours: Black, Blue, Green, Orange, Red, White



253 FLY STOOL

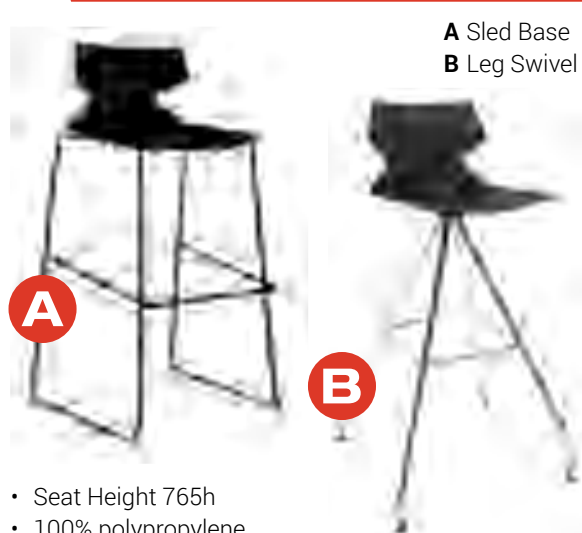

A Sled Base
B Leg Swivel

- Seat Height 765h
- 100% polypropylene
- Strong 12mm solid base frame or 16mmx2mm gauge tubular 4 leg swivel frame
- Powder coated black frame

Weight Rating:

Konfurb guaranteed to 130kg

Sitting Hours:

Konfurb indicative 3-4 daily

5 year guarantee

Stock colours: Black, White

Indent colours: Blue, Green, Grey, Orange, Red

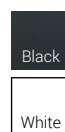

509 GAME CHAIR



Options

A - Skid Base
B - 4 Legs
C - Barstool

- Chair Overall: 450w x 810h x 460d • Seat 460h
Stool Overall: 450w x 1080h x 460d • Seat 750h
- 140kg weight rating • 3+ sitting hours per day
 - 10 year guarantee • Stacks up to 30 chairs on a trolley
 - Large seat & back moulded for comfort
 - Strong, rigid frame that is light to carry
 - Skid Chair feet double as connectors
 - Frame colours - Black, white, silver & chrome



Charcoal & White chairs available with upholstered seats & backs in Breathe Fabric - See page 70, Black, Tomato Red, Lime Green, Bright Orange, Sky Blue, Slate Grey or Plum

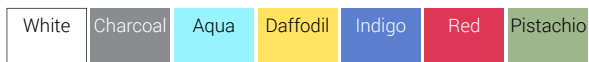

271 DIVO STOOL



500w x 460d x 650h or 750h

- Italian design
- Seat & back made from recyclable polypropylene
- 25mm square anodised aluminium legs
- UV treated
- Stackable
- Indoor and outdoor use
- 2 year warranty

272 CEEMU STOOL



430w x 520d x 650-800h

- Polypropylene seat
- Powdercoated or chromed frame
- Colours - White, Black, Lime
- 2 year warranty

206 SAI CHAIR



480w x 510d x 460h

- Italian design
- Air moulded polypropylene reinforced with fibreglass to provide superior strength
- UV treated • Stackable
- Indoor and outdoor use
- 2 year warranty

215 CEEMU CHAIR



780h x 440w x 450d • Seat 440h

- Polypropylene seat
- Powdercoated or chrome frame
- Indoor chair
- Stackable
- Colours - White, Lime, Black
- 2 year warranty

251 BURO MEG CHAIR

**Specifications:**

Overall: 500w x 560d x 800h
 Back: 420w x 380h
 Seat: 480w x 420d - Height: 445h



- Stackable
- 100% lightweight Polypropylene
- Free trolley with every 32 Meg chairs ordered
- UV protected for outdoor use
- Tested to ANSI/BIFMA x5.1-2011 General-Purpose Office Chairs

Options

- Additional trolleys can be purchased as required

Recommended Stack Heights:

Floor: 8 Chairs

Trolley: 10 Chairs



230 SWOON CHAIR

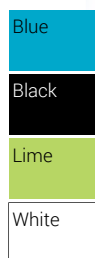

810h x 420w x 440d • Seat 450

- Polypropylene
- Stackable
- Suitable for indoor & outdoor use
- Colours - Blue, Black, Lime and White
- 2 year warranty

199 COOL CHAIR



820h x 525w • Seat 450h

- Suitable for indoor and outdoor use
- Glass reinforced polypropylene
- UV treated
- Stackable
- 120kg / 2 hours
- 5 year warranty

514 BONN CHAIR



910h x 430w x 430d • Seat 440h

- Stainless steel frame
- Stackable

Colours:

Natural Timber
 Black with ply edge detail
 White with ply edge detail

- 2 year warranty

234 BURO ENVY CHAIR



Polypropylene



Black White Green Red



- Stackable
- Quality chrome plated tubular frame
- Linkable
- Free trolley with every 40 Envy ordered
- Supported by the internationally recognised Global GreenTag
- Tested to ANSI/BIFMA x5.1-2011 General-Purpose Office Chairs

Options

- Additional trolleys can be purchased as required

Specifications:

Overall 500w x 550d x 830h
 Back 480w x 350h
 Seat 445w x 460h x 480h

Recommended Stack Heights:

Floor 10 Chairs
 Trolley 25 Chairs



233 BURO MAXIM CHAIR



Vinyl Polypropylene Back

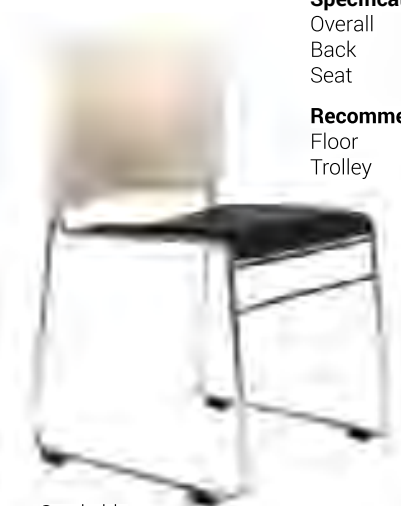

Specifications:

Overall 480w x 445d x 830h
 Back 480w x 350h
 Seat 420w x 455d x 480h

Recommended Stack Heights:

Floor 10 Chairs
 Trolley 25 Chairs

- Stackable
- Quality chrome plated tubular frame (Option of black or white back)
- Quality black powder coated frame (Black back only)
- Upholstered black vinyl seat and strong polypropylene back
- Linkable
- Free trolley with every 35 Maxim ordered
- Supported by the internationally recognised Global GreenTag
- Tested to ANSI/BIFMA x5.1-2011 General-Purpose Office Chairs

Options

- Additional trolleys can be purchased as required



323 BURO QUAD CHAIR



Specifications:

Overall 500w x 510d x 775h
 Back 440w x 390h
 Seat 440w x 420d x 440h

Recommended Stack Heights:

Floor 10 Chairs
 Trolley 25 Chairs

- Stackable
- Quality black powder coated frame
- Durable polypropylene shell
- Generous size shell
- Free trolley with every 20 Quad chairs ordered

Options

- Linking attachment

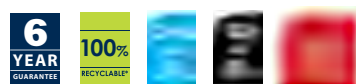

504 VISION CHAIR

Options

- A - No Arms
- B - No Arms / Mesh Back
- C - With Arms
- D - With Arms / Mesh Back



475w x 850h x 500d • Seat 475h

Big comfortable chair for all your visitors.

- 140kg weight rating • 6+ sitting hours per day
- 5 year guarantee • Stackable
- Fully welded frame in Black or Silver powdercoating or chrome
- Double layer comfort zone cushioning

Options - 4 legs • 4 legs with arms • Mesh backs
Available in Breathe Fabrics

505 RAZ CHAIR

Options

- A - 4 Legs - No Arms
- B - 4 Legs - With Arms
- C - Sled Base - No Arms
- D - Sled Base - With Arms



450w x 840h x 470d • Seat 475h

- 140kg weight rating • 6+ sitting hours per day
- 5 year guarantee • Can stack 6 high
- Italian styled back • Strong fully welded frame
- Comfortable NZ cushioning

Options - 4 legs with or without arms
- Skid base with or without arms
Available in Breathe Fabrics

506 QUE CHAIR

Options

- A - 4 Legs - No Arms
- B - 4 Legs - With Arms
- C - Sled Base - No Arms
- D - Sled Base - With Arms



450w x 840h x 470d • Seat 475h

- 140kg weight rating • 6+ sitting hours per day
- 5 year guarantee • Stackable 6 high (excluding arms)
- Dynamic backrest shaped for superb comfort
- Contemporary square styling
- Fully welded frame in Black or Silver powdercoating and Chrome

Options - 4 legs with or without arms
- Skid base with or without arms
Available in Breathe Fabrics

BREATHE FABRIC COLOURS



673 MS2 SUPER STACKER



- 765h x 400w x 400d • Seat 480h
- 40mm foam seat
 - 19mm square frame
 - Curved back
 - Fabric 0.6m
 - Stackable
 - Optional extras - links - tablet arm

674 MS3 SUPREME STACKER



- 765h x 400w x 400d • Seat 480h
- 40mm foam seat - Fabric 0.6m
 - 60mm foam seat - Fabric 0.7m
 - 32mm heavy duty round frame
 - Curved back
 - Stackable
 - Optional extras - links - tablet arm

678A LEXIS CHAIR WITH ARMS



- 770h x 480w x 500d • Seat 440h
820h x 480w x 500d • Seat 490h
- 32mm round frame
 - Flat seat
 - Not stackable
 - 2 heights - 440mm or 490mm seat height
 - Fabric 1m

678B LEXIS CHAIR NO ARMS



- 770h x 480w x 500d • Seat 440h
820h x 480w x 500d • Seat 490h
- 32mm round frame
 - Flat seat
 - Stackable
 - 2 heights - 440mm or 490mm seat height
 - Fabric 1m

684 NOMAD CHAIR 4 LEGS



A - No Arms
B - With Arms

- 815h x 430w x 460d • Seat 480h
- Available with or without arms
 - 25mm round steel frame
 - Stackable
 - Fabric 0.7m

686 NOMAD CHAIR SKID BASE



A - No Arms
B - With Arms

- 815h x 430w x 460d • Seat 480h
- Available with or without arms
 - 25mm round steel frame
 - Neither are stackable
 - Fabric 0.7m

676 ASCOT CHAIR 4 LEGS



A - No Arms
B - With Arms

- 850h x 430w x 470d • Seat 480h
- Available with or without arms
 - 25mm round frame
 - Curved seat
 - Stackable
 - Fabric 0.7m

681 ASCOT CHAIR SKID BASE



A - No Arms
B - With Arms

- 850h x 430w x 470d • Seat 480h
- Available with or without arms
 - 25mm round frame
 - Curved seat
 - Neither are stackable
 - Fabric 0.7m

688 APOLLO CHAIR WITH ARMS



- 770h x 480w x 500d • Seat 440h
- 820h x 480w x 500d • Seat 490h
- 32mm round frame
- Curved seat
- Not stackable
- 2 heights - 440mm or 490mm seat height
- Fabric 1m

689 APOLLO CHAIR NO ARMS



- 770h x 480w x 500d • Seat 440h
- 820h x 480w x 500d • Seat 490h
- 32mm round frame
- Curved seat
- Stackable
- 2 heights - 440mm or 490mm seat height
- Fabric 1m

697 MAYFAIR CHAIR WITH SKID BASE



- 765h x 525w x 470d • Seat 430h
- 32mm round frame
- Flat seat
- Not stackable
- Fabric 1.5m
- Sled base

- A** - No Arms
- B** - With Arms

SEE PAGES 128-132 FOR FABRIC CHOICES

690 MAYFAIR CHAIR WITH ARMS

- 765h x 525w x 470d • Seat 430h
- 32mm round frame
 - Flat seat
 - Not stackable
 - Fabric 1.5m

691 MAYFAIR CHAIR NO ARMS

- 765h x 525w x 470d • Seat 430h
- 32mm round frame
 - Flat seat
 - Not stackable
 - Fabric 1.5m

692 PARKLANE CHAIR WITH ARMS

- 765h x 525w x 470d • Seat 430h
- 32mm round frame
 - Contoured seat
 - Not stackable
 - Fabric 1.5m

693 PARKLANE CHAIR NO ARMS

- 765h x 525w x 470d • Seat 430h
- 32mm round frame
 - Contoured seat
 - Not stackable
 - Fabric 1.5m

648 BURO LINDIS CHAIRS



Specifications:

Overall: 520w x 610d x 840h
 Back: 470w x 390h
 Seat: 470w x 490d - Height: 450h



A

4 LEGS
NO ARMS

Specifications:

Overall: 660w x 620d x 850h
 Back: 470w x 390h
 Seat: 470w x 490d - Height: 460h



B

4 LEGS
WITH ARMS

Specifications:

Overall: 660w x 615d x 845h
 Back: 470w x 385h
 Seat: 460w x 480d - Height: 460h



C

SLED

- Generous size seat and back
- PU moulded foam seat and high density foam back
- Reflective silver powder coat frame

Options

- Chairs are available with no arms
- Arms are Black Polypropylene
- 40mm glides for extra seat height
- Customer specified fabric

MESH

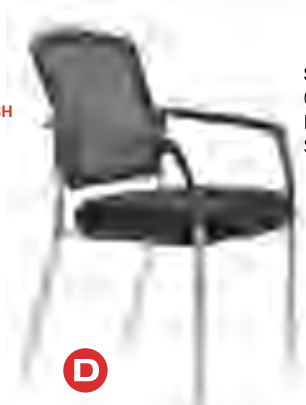

D

Specifications:

Overall: 650w x 645d x 900h
 Back: 480w x 445h
 Seat: 460w x 480d - Height: 455h

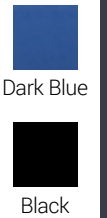

651 ERGOCARE BELLA CHAIR

Specifications:

Overall: 595w x 675d x 890h
 Back: 420w x 530h
 Seat: 535w x 485d - Height: 470h



- Strong solid wood white maple coloured frame
- Generous & supportive seat & back
- Heavy duty 2 pack polyurethane lacquer
- Quality high density foam
- Gin Rummy - gravel upholstery
- Adjustable height levelling guides
- Tested to ANSI/BIFMA x5.162011 General-Purpose Office Chairs

Options

- Customer specified upholstery



652 KONFURB HADY CHAIR

Specifications:

Overall: 600w x 615d x 845h
 Back: 530w x 390h
 Seat: 490w x 470d - Height: 455h



- 4 leg wooden base
- High density soft pile foam
- Full 5 year guarantee (excluding upholstery)

Options

- Customer specified fabrics



Gabriel Fighter - Charcoal

660 BURO ESSENCE CHAIR



Specifications:

Overall: 610w x 620d x 840h
 Back: 460w x 360h
 Seat: 470w x 490d - Height: 480h



- Stackable
- Generous size seat and back
- High density polyurethane moulded foam
- Black powder coated frame

Options

- Customer specified fabric
- Chrome frame



Dark Blue



Black



655 KONFURB NEO CHAIR



Specifications:

Overall: 680w x 630d x 855h
 Back: 605w x 450h
 Seat: 680w x 490d - Height: 410h



Gabriel Fighter - Charcoal

- Strong 4 leg wooden base
- High density soft pile foam (Meets CAL 117 Section A Part I & Section D Part II)
- Full 5 year guarantee (excluding upholstery)

Options

- Customer specified fabrics



232 BURO MARIO CHAIR



Specifications:

Overall: 545w x 595d x 815h
 Back: 450w x 350h
 Seat: 430w x 470d - Height: 460h



- Strong steel silver powder coated skid base frame
- Stackable, linkable
- Generous size seat and back
- Free trolley with every 25 Mario chairs ordered
- Colours: Dark Blue, Black

Options

- Customer specified fabric
- Chrome frame

Recommended Stack Heights:

Floor 8 Chairs
 Trolley 15 Chairs



Dark Blue



Black



228 BURO BANQUET CHAIR



Specifications:

Overall: 440w x 550d x 875h
 Back: 395w x 390h
 Seat: 410w x 380d - Height: 465h



- Stackable
- Generous size seat and back
- High density polyurethane moulded foam
- Chrome frame

Options

- Customer specified fabric
- Chrome frame
- 40mm glides for extra seat height

Recommended Stack Heights:

Floor 8 Chairs
 Trolley 15 Chairs



Black



658 MONDO JAVA MID-HIGH



Specifications:

Mid Overall: 580w x 590d x 850h
 High Overall: 580w x 590d x 950h
 Back: 420w x 400h
 Seat: 440-560h

- Delivered flat packed - tool free assembly
- Generous size seat & contoured back for comfort & support
- Gas lift seat height adjustment
- Strong nylon 5 star base with twin wheel hooded castors
- Height adjustable back/lumbar
- Independently adjustable seat & back tilt - free floating or lockable
- High density moulded 'dual foam' seat

Options

- Polished aluminium base
- Height and width adjustable arms
- Customer specified fabric



659 MONDO JAVA MESH



Specifications:

Overall: 580w x 590d x 890h
 Back: 455w x 430h
 Seat: 440-560h

- Delivered flat packed - tool free assembly
- Generous size seat, breathable mesh back for comfort & support
- Gas lift seat height adjustment
- Strong nylon 5 star base with twin wheel hooded castors
- Height adjustable back/lumbar
- Independently adjustable seat & back tilt - free floating or lockable
- High density moulded 'dual foam' seat

Options

- Polished aluminium base
- Height and width adjustable arms
- Customer specified fabric



647 BURO IMAGE



Specifications:

Overall: M600w x 590d x 870h
 Back: 430w x 410h
 Seat: 470w x 470d - Height: 450-580h

- Height adjustable back/lumbar
- Polyurethane moulded foam
- 60mm twin wheel castors
- Depth adjustable back

Options

- Polished aluminium base
- Architectural 270mm gas lift
- Height adjustable chrome foot ring
- Height and width adjustable arms
- Customer specified fabric



237 BURO BRIO II



Specifications:

Overall: 635w x 635d x 1025h
 Back: 480w x 575h
 Seat: 500w-500d - Height 450-570h

- Adjustable seat height
- Ratchet height adjustable lumbar support
- High density quality seat foam
- Seat & back tilt with lock adjustment
- Body weight tension adjustment
- Height adjustment PU capped arm rests

Options

- Polished aluminium base
- Customer specified & indent fabric (seat only)



240 BURO ROMA MID BACK



Specifications:

Overall: 630w x 600d x 1120h
 Back: 430w x 445h
 Seat: 460-590h

- 130 x 48mm gas lift
- Ratchet height adjustment back/lumbar
- Adjustable seat & back rest angle - free floating or lockable
- Polyurethane moulded foam
- D1 nylon base
- 60mm twin wheel castors

Options

- Height and width adjustable arms
- Polished aluminium base
- Customer specified fabric



Dark Blue



Charcoal



Black



Green



Red



241 BURO ROMA HIGH BACK



Specifications:

Overall: 630w x 600d x 1180h
 Back: 430w x 445h
 Seat: 465-595h

- 130 x 48mm gas lift
- Ratchet height adjustment back/lumbar
- Adjustable seat & back rest angle - free floating or lockable
- Polyurethane moulded foam
- D1 nylon base
- 60mm twin wheel castors

Options

- Seat slide mechanism
- Height and width adjustable arms
- Polished aluminium base
- Customer specified fabric



Dark Blue



Charcoal



Black



Green



Red



650 BURO AURA ERGO +



Specifications:

Overall: 630w x 610d x 1030h
 Back: 430w x 560h
 Seat: 490w x 470d - Height: 450-580h
 Seat Depth: 460-510d

- Adjustable seat height
- Ratchet height adjustment back/lumbar
- Independently adjustable seat & back tilt - free floating or lockable
- Depth adjustable seat slide
- Polyurethane moulded foam
- Metal/reinforced base
- 60mm twin wheel castors

Options

- Polished aluminium base
- Height and width adjustable arms
- Customer specified fabric



Dark Blue



Charcoal



Black



Green



Red



654 BURO PERSONA 24/7



Specifications:

Overall: 700w x 590d x 1070h
 Back: 530w x 640h
 Seat: 520w x 490d - Height: 480-580h
 Seat Depth : 475-525d

- Body weight tension adjustment
- Adjustable seat height with superior heavy duty gas lift
- Ratchet height adjustable back/lumbar
- Independently adjustable seat & back tilt - free floating or lockable
- Dedicated forward seat tilt & lock adjustment
- Depth adjustable seat slide
- Height and width adjustable arms
- High density polyurethane moulded foam
- Heavy duty nylon base and 60mm castors

Options

- Polished aluminium base
- Customer specified fabric



Black Leather Seated



Dark Blue



Black



239 BURO METRO



Black

Specifications:
 Overall: 630w x 610d x 995h
 Back: 470w x 530h
 Seat: 520w x 490d
 Seat Height: 465-595h
 (480-610h with seat slide)
 Seat Depth: 475d
 (455-505d with seat slide)

- Adjustable seat height
- Ratchet height adjustable back
- Independently adjustable seat & back tilt - free floating or lockable
- High density polyurethane moulded foam seat
- Black nylon base

Options

- Polished aluminium base
- Height and width adjustable arms
- Depth adjustable seat slide
- Customer specified fabric (seat only)



244 BURO METRO II



Black

Specifications:
 Overall: 630w x 610d x 995h
 Back: 470w x 530h
 Seat: 520-490h
 Seat Height: 470-660h

- AFRDI Certified Gas lift
- Ratchet height adjustable back
- Independently adjustable seat & back tilt - free floating or lockable
- Black nylon base
- High density polyurethane moulded foam seat
- 60mm twin wheel castors

Options

- Height and width adjustable arms
- Polished aluminium base
- 3 lever with seat slide
- Customer specified fabric (seat only)



662 BURO MENTOR



Black

Specifications:
 Overall: 635w x 640d x 1020h
 Back: 485w x 575h
 Seat: 515w x 480d
 Seat Height: 475-595h
 Seat Depth: 425-475d

- Polyurethane moulded foam seat
- Synchronised seat & backrest angle with 4 position locking adjustment
- Superior self weighting tension adjustment, adjusts automatically
- Depth adjustment seat slide
- Black nylon of polished aluminium base
- Adjustable lumbar support
- 60mm soft PU castors

Options

- Height, depth & angle adjustable arms with soft PU pads
- Customer specified fabric

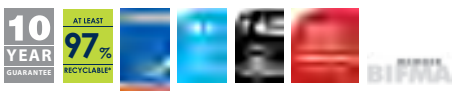

665 BURO VELA HIGH BACK



Black

Specifications:
 Overall: 670w x 640d x 1020h
 Back: 485w x 590h
 Seat: 515w x 480d
 Seat Height: 475-595h
 Seat Depth: 425-475d

- Contoured polyurethane moulded foam seat
- Synchronised seat & backrest angle with 4 position locking adjustment
- Superior self weighting tension adjustment, adjusts automatically
- Depth adjustment seat slide
- Black nylon base & 60mm soft PU castors
- Adjustable lumbar support
- Height, depth & angle adjustable arms with soft PU pads

Options

- Vela Headrest - Black
- Polished aluminium base
- Customer specified fabric

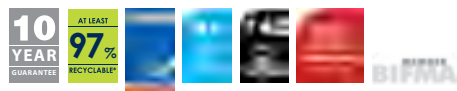

657 BURO EVEREST



Specifications:

Overall: 650w x 630d x 1140h
 Back: 490w x 500h
 Seat: 520w x 490d
 Seat Height: 480-580h
 Headrest: 340w x 175h



Black
Leather



Mesh

- Adjustable seat height
- Synchronised seat & backrest angle with locking adjustment
- Depth adjustable back
- High density polyurethane moulded foam
- Body weight tension adjustment
- Height and width tension adjustment arms
- Height adjustment headrest
- 60mm twin wheel castors
- Polished aluminium base
- Superior heavy duty gas lift with 'Lifetime Guarantee'

Options

- AFRDI Metal reinforced base



666 BURO CHALLENGER



Specifications:

Overall - 680w x 675d x 1140h
 Back - 515w x 715h
 Seat - 555w x 505d
 Seat Height: 440-530h



Black

- Adjustable seat height
- Synchronised seat & backrest angle with 4 position locking adjustment
- Body weight tension adjustment
- Height and width tension adjustment arms
- Polished chrome steel base
- Soft touch, hard wearing polyurethane upholstery
- 60mm castors



668 BURO DYNA STOOL



Specifications:

Overall: 420w x 410d x 600h
 Seat: 400w x 410d
 Seat Height: 600-880h



Dark Blue



Black



Red

- Moulded foam seat
- Auto return swivel seat
- Gas lift height adjustment

Options

- Customer specified fabric (seat)



669 BURO ACTIVE METRO II CONNECT



Specifications:

Overall: 640w x 680d x 935h
 Back: 430w x 460h
 Seat: 520w x 490d x 470-600h



Black

- Ratchet height adjustable back
- Polyurethane moulded foam
- Depth adjustable back
- 360 degree pivoting base
- Wide nylon base for extra balance

Options

- Customer specified fabric (seat only)
- Architectural 200mm gaslift



671 BURO REVO

Specifications:
Overall: 540w x 500d x 555h
Seat: 350dia Seat Height: 490-675h



Black Vinyl

- Adjustable seat height
- High density polyurethane moulded foam

Options

- Architectural 270mm gas lift
- Height adjustable chrome foot ring
- Customer specified fabric



670 BURO ACTIVE REVO

Specifications:
Overall: 640w x 640d x 515h
Seat: 350dia Seat Height: 515-700h



Black Vinyl

- Adjustable seat height
- High density polyurethane moulded foam
- 360 degree pivoting base
- Wide nylon for extra balance

Options

- Customer specified fabric



764 BURO KNEE

Specifications:
Overall: 615w x 590d x 645h
Knee Rest: 430w x 250d
Seat: 430w x 340d Seat Height: 500-680h



Black

- Adjustable seat height
- High density polyurethane moulded foam

Options

- Various height gas lifts
- Customer specified fabric



662 CHAIR MATS



A

- A** 900 x 1200
- B** 1100 x 1300

- Protect your carpets from wearing out quickly in the areas where your chairs are rolling everyday.
- Translucent mats with grips to ensure they do not 'walk'.
- Guaranteed against cracking and crazing

665 FOOTRESTS

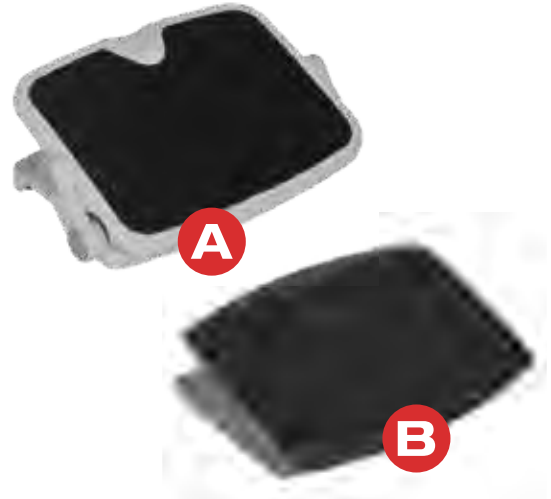

A

B

A Footrest Platinum

- High grade moulded plastic
- Height & tilt adjustable
- Platinum colour premium rubber surface

Measurements

Footprint: 450mm wide x 360mm deep

B Footrest Black

- High grade moulded plastic
- Tilt adjustable only
- Black colour

Measurements

Footprint: 450mm wide x 360mm deep



SOFT FURNISHINGS

CONTENTS

Fritters, Bean Bags & Stools	83-84
Ottomans	85-88
Couches	89-90
Buro Chairs & Sofa	91

472 FRITTERS

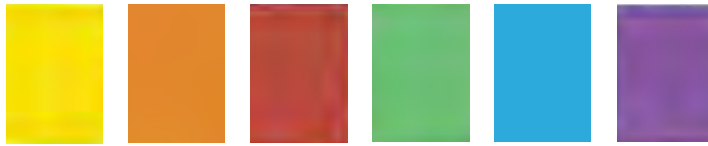

Yellow Orange Red Mint Turquoise Purple



- Size - 500mm diameter x 80mm thick
- Heavy duty foam with vinyl covering
 - Colours - Yellow, Orange, Red, Mint, Turquoise, Purple
 - 12 month warranty - excludes zip and fabric

473 TEARDROP BEAN BAGS



Black Blue Lime Red Orange Chocolate Burgundy

- Premium canvas outdoor fabric
- Black piping feature
- Liner inside containing beans
- Air vents in base
- 1 Year Guarantee - Excludes fabric & zips
- Colours - Black, Blue, Lime, Red, Orange, Chocolate & Burgundy

472 FRITTER TROLLEYS



- A** Single
- B** Double
- C** Triple (as pictured)
 - Holds 10 Frittlers per row
 - 25mm Melteca base
 - Mobile with locking castors
 - Some basic assembly may be required

236 CUBE STOOLS

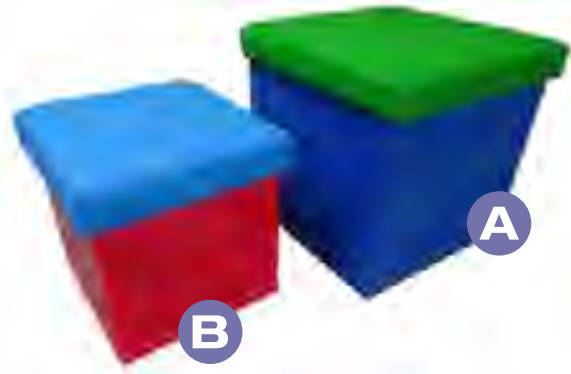

PACIFICA VINYL



- A** 400W x 400D x 400H
- B** 300W x 300D x 320H
 - Melteca base (choose colour)
 - Glides on base
 - Pacifica Vinyl tops
 - Can be made with fabric of choice

519 STORAGE SEATS

Storage seats can be made in different combinations including our 4 standard models.

- 18mm Melteca construction
- Glides on base
- 50mm foam seat covered in Pacifica Vinyl
- Can be made with fabric of choice

- A** - 885L x 400D x 450H with 6 Small Tote Trays
- B** - 1300L x 400D x 450H with 9 Small Tote Trays
- C** - 820L x 400D x 450H with 2 Cube Crates
- D** - 1200L x 400D x 450H with 3 Cube Crates



PACIFICA VINYL

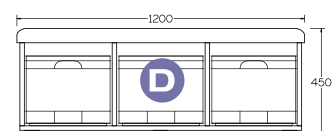
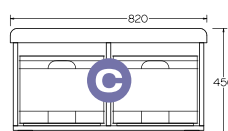
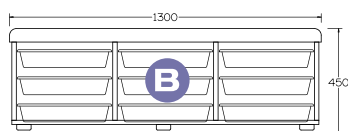
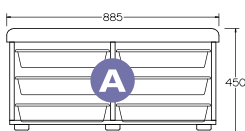
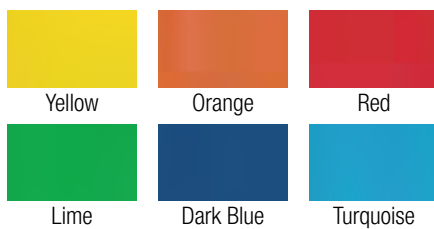

460 QUARTERS & EIGHTHS OTTOMANS



- A** use a 900 diameter table
- B** use a 1200 diameter table

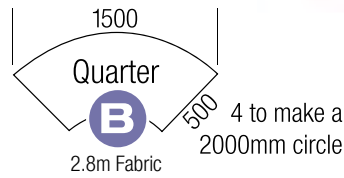
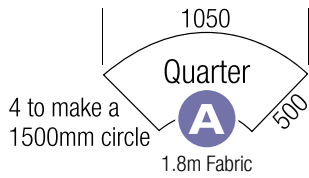

- All 350, 400 or 450 high
- With glides only

468 PETAL OTTOMANS



- 600 diameter
- All 350, 400 or 450 high
 - With glides only
 - 1.8m Fabric
 - Fits together with 462 Round 600mm Ottoman



SEE PAGES 128-132 FOR FABRIC COLOUR CHOICES

471 RECTANGLE OTTOMANS



Rectangles

- 1000 x 500 • 1.6m
- 1200 x 600 • 2.5m
- 1500 x 600 • 3.1m
- 1800 x 600 • 3.7m

Or made to your specifications

- All 350, 400 or 450 high
- Available with glides or steel legs

461 CURVED OTTOMANS



- 1700L x 600D
- 3.0m Fabric

- All 350, 400 or 450 high
- Available with glides or steel legs

SEE PAGES 128-132 FOR FABRIC COLOUR CHOICES

470 SQUARE OTTOMANS



450 x 450 • 1.0m Fabric
 900 x 900 • 2.0m Fabric
 Or made to your specifications

- All 350, 400 or 450 high
- Available with glides or steel legs

463 PENTAGON OTTOMANS

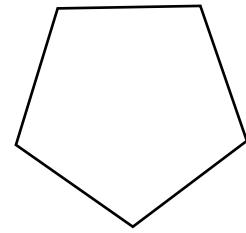

550 diameter
 • 1.5m Fabric
 • All 350, 400 or 450 high
 • With glides only

462 ROUND OTTOMANS



600 diameter • 1.8m Fabric
 900 diameter • 2.5m Fabric
 1000 diameter • 2.7m Fabric
 1200 diameter • 3.2m Fabric

- All 350, 400 or 450 high
- With glides only



496 OTTOMANS WITH BACKS

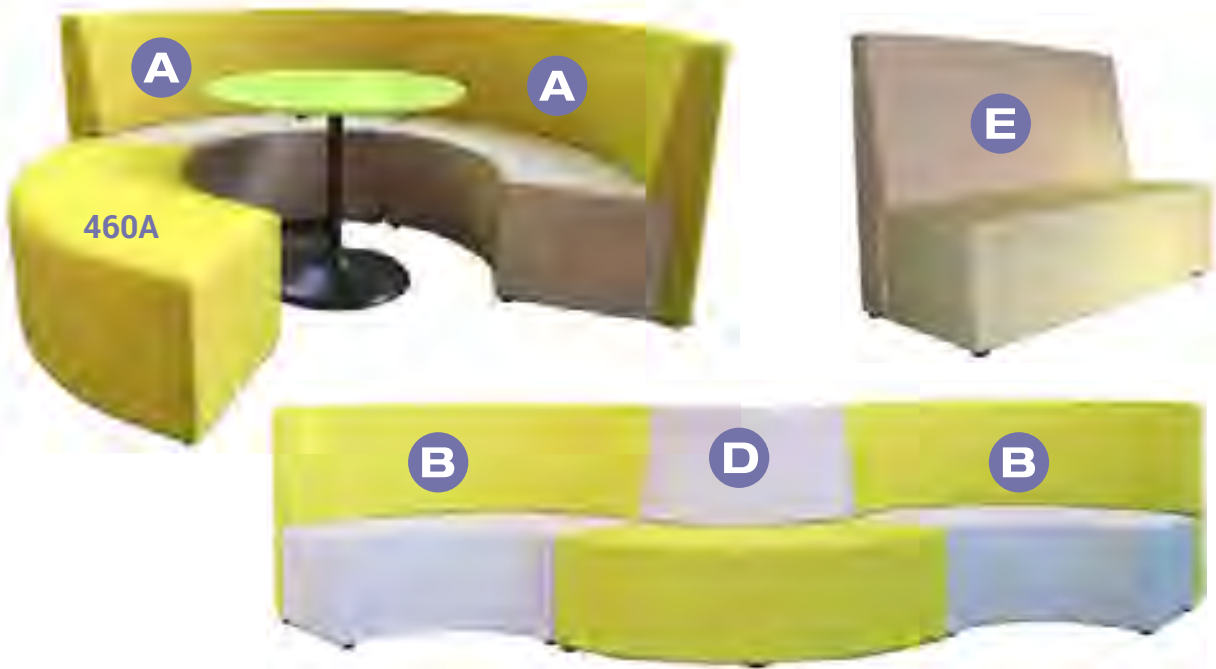

Seat depth 500mm
 Seat back heights 900mm
 Overall depth 600mm
 With Glides or Steel legs

- A** 1130mm curve - Outer back
- B** 1500mm curve - Outer back
- C** 1130mm curve - Inner back
- D** 1500mm curve - Inner back
- E** 1500mm straight

We can add backs to most of the shaped ottomans
 - Option to use contrasting fabrics

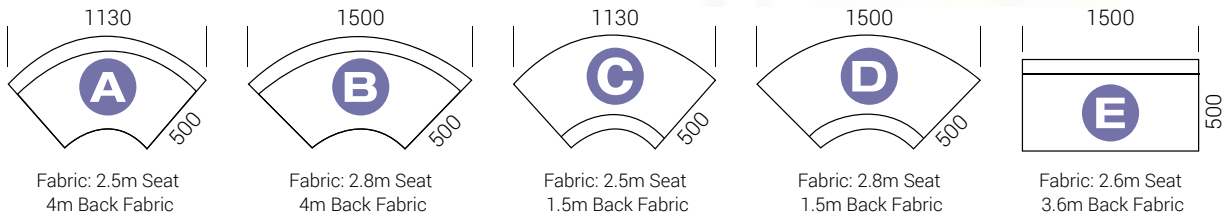
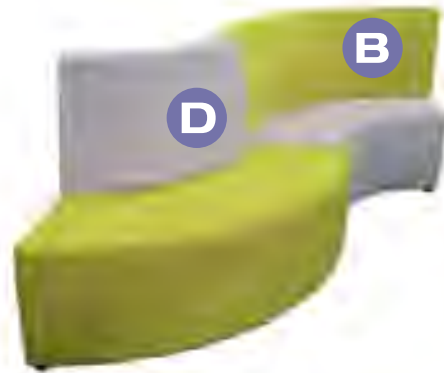

518 POD OF OTTOMANS



1800L x 1200W

- 6 piece pod
- Plastic glides on base
- 12m Fabric - one colour
- 13m Fabric - 2 colours

Comes complete with:

- 4 - 600 x 600 corners
- 2 - 600 x 600 squares with backs
- Seat height - 450mm high

498 SIENNA COUCHES



Feet Options

- Standard with 50x50mm square foot on fixing plate
- Upgrade to Full Steel 25x25mm frame with either 25mm or 50mm square feet
- Upgrade to Full Steel 25x25mm frame with skid base

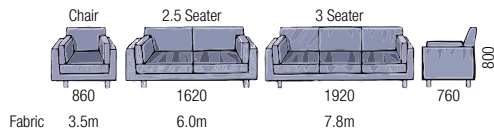

497 JIVE COUCHES



Feet Options

- Standard with 50x50mm square foot on fixing plate
- Upgrade to Full Steel 25x25mm frame with either 25mm or 50mm square feet
- Upgrade to Full Steel 25x25mm frame with skid base

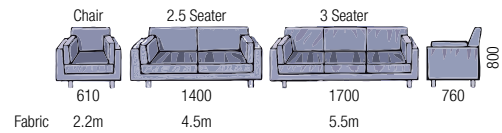

529 SEDAN COUCHES



- NZ Pine carcass
- Elastic webbed seat
- Swivel glides on feet
- 19mm \varnothing fully welded frame
- Chrome or powder coated finish
- Seat height 435mm

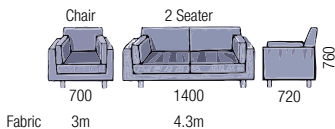

Chair Contrasting seat

- 0.8m seat
- 2.2m carcass

Couch Contrasting seat

- 1.4m seat
- 3m carcass

486 APOLLO COUCHES



Feet

- 50 x 50 x 100mm high square legs
- Powder coated Silver Star

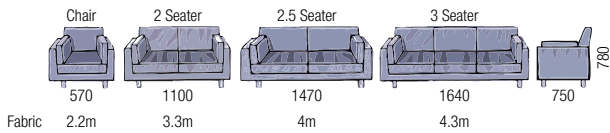

842 SEIGEN COUCHES



Feet Options

- Wooden feet 150mm high

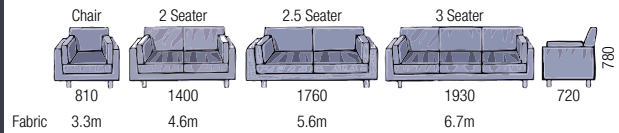

840 MANHATTAN COUCHES



Feet

- 50 x 50 x 100mm high square legs
- Powder coated Silver Star

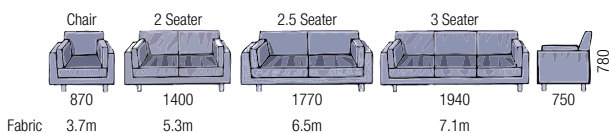

844 PLUTO COUCHES



Feet Options

- Tapered wood 100mm high
- 50 x 50 x 100mm high square legs
- Powder coated Silver Star

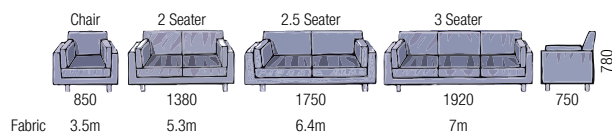

694 BURO POLO CHAIR



Features

- Generous size seat
- High density soft pile foam

Options

- Customer specified & indent fabric
- 2.5 seater available

Specifications

Overall 670 x 600 x 740
 Back 420 x 310
 Seat 500 x 500
 Seat height 440

PU

Black



695 BURO DELTA CHAIR



Features

- Solid wooden legs
- High density soft pile foam
- PU upholstery

Options

- Chrome steel legs
- Customer specified fabric

Specifications

Overall 770 x 790 x 830
 Back 530 x 355
 Seat 530 x 520
 Seat height 475

PU

Black



696 BURO DELTA 2.5 SEATER SOFA



Features

- Solid wooden legs
- High density soft pile foam
- PU upholstery

Options

- Chrome steel legs
- Customer specified fabric

Specifications

Overall 1670 x 790 x 830
 Back 1430 x 355
 Seat 1430 x 520
 Seat height 475

PU

Black





OFFICE FURNITURE

CONTENTS

- iQuad Office Furniture 93-94
- Workstations & Desks..... 95-98
- Reception & Library Desks..... 99
- Ergonomic Desking & Accessories .. 100-102
- iQuad Desk Units 103
- iQuad Mobiles & Credenzas 104
- iQuad Storage..... 105-106
- Modular Units..... 107-108
- Meeting Tables 109-110
- Bar Leaners 111
- Coffee Tables 112
- Europlan 113-114



Welcome to our new range of office furniture. We have developed this range that is functional, flexible and attractive. This range has many different features that will fit into any office, whether it is the small business, the CEO, an office with many people and of course for the individual that wants an office at home. Having the range with Desks, Workstations, Meeting tables, Coffee tables and multiple storage units makes this easy

to pick and choose to suit your individual needs. We have used all quality materials, hardware and fittings to ensure that this product lasts the distance. We have also made these in practical sizes that ensure less wastage which in turn means less damage to our precious environment. This also ensures that you are getting a product that is both cost effective, practical and functional.





Hettich is one of the world's largest producers of cabinet hardware and fittings for the residential and commercial markets. Hettich products are at the forefront of design and are well known for exceptional quality, functionality and innovation. In addition to an impressive product range, when you use Hettich products you can have total peace of mind as Hettich fully endorse the drawer and hinge systems with a Lifetime Warranty.

Lifetime warranty on all registered hardware

WORKSTATIONS

We have developed the workstation range so it is a pick & mix.

- Choose your base/leg system, the shape of the top, then the size.
ie 1200 x 600 Left x 1800 x 800 Right
 - Workstation lengths: Standard lengths available 1200, 1800, 2000, 2400, or any increment between 1200L - 2400L.
 - Workstation depths: 600, 700, 750, 800, or any increment.
- Any combinations are available. See graph for better understanding.



STANDARD SIZES

1200 x 1800	1800 x 2000
1200 x 2000	1800 x 2400
1200 x 2400	2000 x 2000
1800 x 1800	2400 x 2400

Specifications required:

- Left and right measurement
- Depth required for each side
- Each workstation comes standard with a cable port in corner
- Cable ports can be added on request

Custom made sizes all P.O.A

TOP OPTIONS

Q300 WORKSTATION

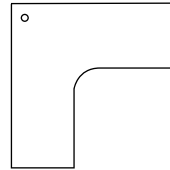

ALPINE WORKSTATION

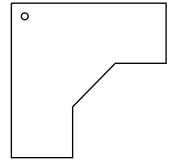

OVAL END WORKSTATION

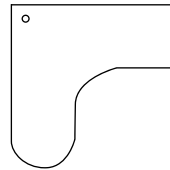

ELE WORKSTATION (SCALLOP)

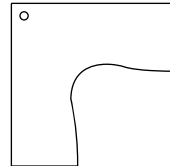

CONTOUR P-END WORKSTATION

P-End requires the length of 2200L

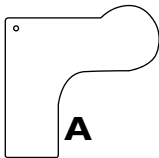

Right Hand 'P'
Facing away

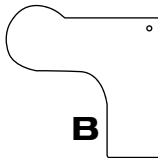

Left Hand 'P'
Facing away

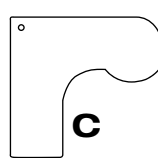

Right Hand 'P'
Facing

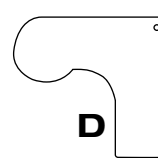

Left Hand 'P'
Facing

BASE/LEG OPTIONS

533 SLAB END



- 25mm tops with rounded corners
- Complete with 400mm modesty panel
- Full modesty panel can be added on request

806 iQuad



- 25mm tops with square corners
- 50x50 square legs with 50x25 support rails
- Modesty panels can be added

831 iQuad +



- 25mm tops with square corners
- 50x50 square legs with ladder detail
- 50x25 support rails
- Modesty panels can be added

DUO WORKSTATION

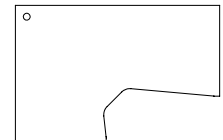
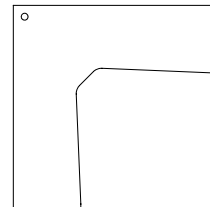



iQuad+



iQuad



SLAB END

807 iQuad MODESTY PANELS

These can be added to desks and workstations

Options

- Steel mesh panels to fit 1200, 1800, 2000L
- 400D Melteca panels
- Full length Melteca panels



DESKS

We have developed the desks to match in with the workstations.

- Choose your base/leg system, the shape of the top, then the size, remembering to note which side the "Ovals & P's" are on.

TOP OPTIONS

STRAIGHT DESK

This practical desk fits well in any symmetrical room.

- **Desk Lengths** 1200, 1600, 1800, 2000, 2200, 2400mm
- **Desk Depths** 600, 700, 750, 800mm



CURVE DESK

This curved front desk adds an inviting impression and extra depth for additional work space.

- **Desk Lengths** 1600, 1800, 2000, 2400mm
- **Desk Depths** 800 to 900mm

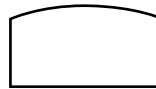

WAVE DESK

An elegant curved desk featuring a deeper work space on one side. Available in left hand or right hand options.

- **Desk Lengths** 1600, 1800, 2000, 2400mm
- **Desk Depths** 600 to 800mm



OVAL END DESK

A user friendly design. Can be used as a meeting end.

- **Desk Lengths** 1600, 1800, 2000, 2400mm
- **Desk Depths** 600, 700, 750, 800mm



P-END DESK

A conference end desk. Ideal for meetings or just additional workspace. Available in left hand or right hand options with the P-end facing or away.

- **Desk Lengths** 2200, 2400mm
- **Desk Depths** 700 deep with 900mm 'P'

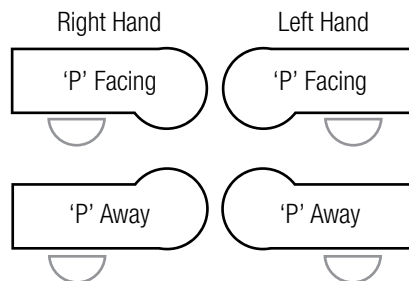

CONTOUR DESK

Comfort curve in middle of desk

- **Desk Lengths** 1600, 1800, 2000, 2400mm
- **Desk Depths** 600, 700, 750, 800mm



BASE/LEG OPTIONS

533 SLAB END



- 25mm tops with rounded corners
- Complete with 400mm modesty panel
- Full modesty panel can be added on request

806 iQuad



- 25mm tops with square corners
- 50x50 square legs with 50x25 support rails
- Modesty panels can be added

831 iQuad +



- 25mm tops with square corners
- 50x50 square legs with ladder detail
- 50x25 support rails
- Modesty panels can be added



iQuad +

807 iQuad MODESTY PANELS

These can be added to desks and workstations

Options

- Steel mesh panels to fit 1200, 1800, 2000L
- 400D Melteca panels
- Full length Melteca panels



Reception and Library desks are a piece of furniture that is always custom made to meet the customer's specification. Every space is different and every requirement is different.

We have a range of ideas, with a range of materials and styles that we can discuss with you and together we can create your own custom made desk.

We are the manufacturer, we can work together to come up with something that is suited to your environment and working situation, so come be creative with Mike's Woodshop...



Corner workstation desk

- With overlay decorative panels

Corner reception desk (left of photo)

- Full modesty panels with decorative strip
- Reception top

Jellybean library desk (right of photo)

- 1500 x 900



Corner workstation desk

- With reception hutch
- Book slot if required



Rectangle workstation desk

- Design you own
- Be brave, be cool!



Corner workstation desk

- With overlay decorative panels



U-Shape library or reception desk

- 50x50mm steel post frame with Melteca inserts
- Overlay decorative panels

565 AGILE ELECTRONIC DESKS



Sizes

1200 x 700
1500 x 800
1800 x 800

Top Colours - White, Silver, Nordic Maple, Atlantic Oak

Frame Colours - Black, White or Silver powder coated finish

FEATURES

- Two column height range 680 - 1130mm (incl. worksurface)
- Smooth silent path, single motor system - so no co-worker disturbance or irritation
- Up and down speed 22mm/sec
- Digital height readout with 4 point memory
- Commercial-grade 25mm worksurfaces are constructed from E1 board melamine with matching PVC edge
- Optional cable trays are available
- 12 year Guarantee on frame and motor
- 100 kg weight rating

STANDARD COLOURS



White Silver Nordic Maple Atlantic Oak

566 AGILE ELECTRONIC WORKSTATIONS



Sizes

1500 x 1500 x 700
1800 x 1800 x 700

Top Colours - White, Silver, Nordic Maple, Atlantic Oak

Frame Colours - Black, White or Silver powder coated finish

FEATURES

- Two column height range 680 - 1130mm (incl. worksurface)
- Single motor - up and down speed 22mm/sec
- Digital height readout with 4 point memory
- Commercial-grade 25mm worksurfaces are constructed from E1 board melamine with matching PVC edge
- Option - cable basket available
- 12 year Guarantee on frame and motor
- 100 kg weight rating

STANDARD COLOURS



White Nordic Maple Atlantic Oak

564 ADJUSTABLE WAVE DESK



Dimensions

Length - 950mm x width 520mm
Height - Adjustable between 740-1040mm

Wave desk is a portable, lightweight sit to stand desk. Its two powder-coated caster wheels makes moving this desk a breeze.

A height adjustable desk with two gas lifts making changing from sit to stand easy. With a fixed MDF desk top.

The desk has a max weight limit of 50kg and it's designed to handle all of your daily work needs. Compact enough to fit in any environment, but big enough to fit all your working needs on it.

526 UPANATOM



The new UPANATOM mobile laptop Sit Stand desk is a compact economical manual solution. Featuring a single lever has assist height adjustable poly propylene platform large enough to suit a 17 inch laptop. Retractable mouse pad & cup holder. Locking castors. Two handles foe easy movability. Extra wide starship base for maximum stability. 10 year warranty.

Specifications

Desk Height: 720mm - 980mm
Overall top: 600mm - 385mm
Foot print: 630x625mm

520 ARISE DESKALATOR

**Specifications**

Small: 680w x 790d x from 150 to 500h
 Medium: 890w x 790d x from 150 to 500h
 Colours: Black or white

Arise Deskalator sits on your existing desk and lets you change posture through the day.
 Scissor structure with gas spring features smooth height adjustment

Features

- Adjusts straight up and down. Always in easy reach
- Gas spring offers smooth supported height transition
- 13 available options for height adjustment
- Wide adjustment to suit all users
- Support groove on the surface to mount smart phone & tablet
- Advanced design avoids any danger of clamping injury
- Easy height adjustment via two activation paddles
- 3 hole mounts for easy-fit single or dual monitor arms
- 10 year warrantee



521 ARISE COMPULATOR



The **Arise Compulator** conveniently clamps to the front of a desk and allows the user to change posture throughout the day

Suitable for desks of various depths from 600mm upwards

Features

- Adjusts straight up and down. Always in easy reach
- Gas spring offers smooth supported height transition
- 13 available options for height adjustment
- Wide adjustment to suit all users
- Support groove on the surface to mount smart phone & tablet
- Advanced design avoids any danger of clamping injury
- Easy height adjustment via two activation paddles
- 3 hole mounts for easy-fit single or dual monitor arms
- 10 year warranty

Specifications

- 800w x 520d
- Height adjustable from 150h to 430h



522 ARISE STANDSOFT MAT



Specifications

Mat width: 800mm x 500mm x 15mm

Stand your way to a healthier way of being. The new Arise Standsoft anti-fatigue mat has been specifically designed to work with the Sylex range of Sit Stand desks. The 100% PU moulded mats provide a platform that transfers downward pressure away from the hips, knees, ankles & feet.

Arise Standsoft bevelled edge reduces any tripping hazards. An intricate embossed leafy design distinguishes Arise Standsoft.

Standsoft is the perfect companion to the Arise ACT 2 desks and a necessity to any one standing over any length of time throughout their day.

525 GLADIUS ARMS

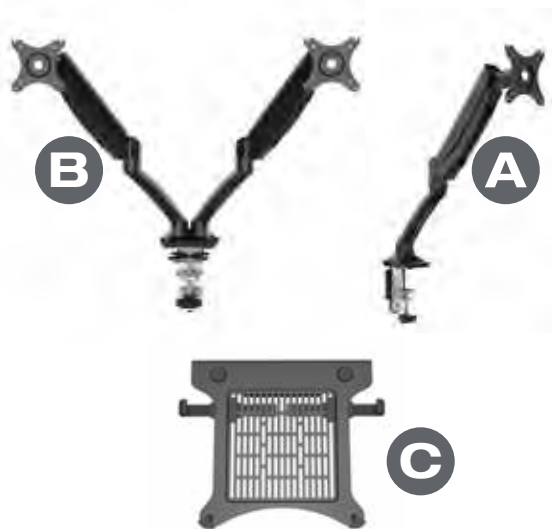

- A** Single Arm
- B** Double Arm
- C** Adapter plate for laptops & iPads

Colours: Black or white

Gladius arms allow mounting of monitors with 75mm or 100mm VESA hole centres.

Available standard in black the Gladius series is also available in white for contract quantities on longer lead times.

On the double version, independent gas height adjustable arms allow you to mount different sized monitors side by side in the same focal plane, avoiding tiring re-focusing and compromised postures.

Features

- Full rotation, 360 degrees at any position
- Up to 30 inch monitor
- 85 degrees upward, 15 degrees downward
- Cable management
- Grommet or clamp mount
- Both clamp and grommet mount included in the box
- Tablet and laptop mounts also available
- 10 year warranty

524 CUTLASS ARMS



- A** Single Arm
- B** Double Arm

Colour: White

The all new Cutlass arms are a step up from the Gladius with contemporary slim styling, better cable management and built in USB ports right on the desktop. Elegant white and black styling in a finish which will transform any office into a modern work hub. A higher adjustment range and an improved desk clamp make this the value choice among monitor mounting options.

Features

- Screen tilt adjustment
- Integrated cable management
- Double USB Ports
- Grommet or clamp mount (both included in the box)
- Made of aircraft aluminium
- Simple and stylish modeling, compact and rugged
- 360° free switch between portrait and landscape orientation
- Supports monitors up to 30"
- Sleek and streamlined appearance perfectly complements any contemporary workstation
- Tablet and laptop mounts also available
- 10 year warranty

Single - Balanced gaslift height adjustable arm
 Double - Dual independent balanced height adjustable arm



DESK UNITS

These units are all at desk height that will create an extension of your desk area, or banked together to create functional storage in your office. All these units come with matching backs so they can also break up a large office into individual areas.

Specifications

- 800W x 600D x 725H
- File drawer unit is 960mm wide
- 25mm Carcass & shelves
- 18mm drawer fronts and doors
- Melteca matching backs
- 50x50x80mm high steel square feet
- Drawer hardware - see below
- Cupboards have smooth action 'soft close' hinges

Add locks if required



808 CUPBOARD

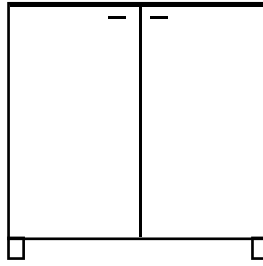

- 800W x 600D x 725H
• 1 adjustable shelf

809 SHELVING UNIT

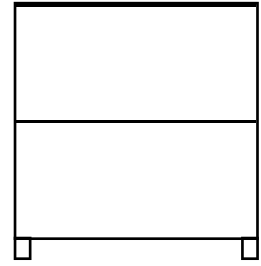

- 800W x 600D x 725H
• 1 adjustable shelf

810 DRAWER UNITS

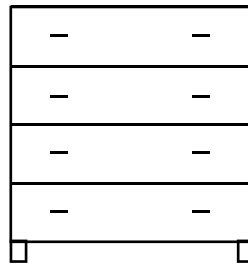

- 800W x 600D x 725H
• 4 drawers

811 FILES & DRAWERS

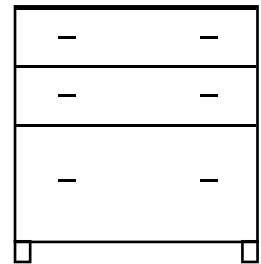

- 960W x 600D x 725H
• 2 drawers
• 1 double file



STANDARD DRAWERS

- Steel sided Multi tech drawers
- 12mm white Melteca bases
- Capacity up to 25kg

FILE DRAWERS

- Heavy duty Innotech steel drawer system
- Heavy duty hanging file rails
- 16mm white Melteca base
- Smooth action soft closing drawer



Mobile units are designed to fit under your workstation and desks

- 490W x 490D x 625H
- Standard drawers
- Steel sided Multi tech drawers
- 12mm white Melteca bases
- Capacity up to 25kg

Add locks if required



812 MOBILE UNIT

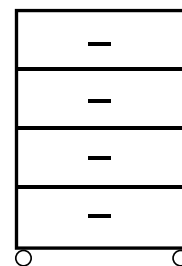

- 4 drawer

813 MOBILE UNIT

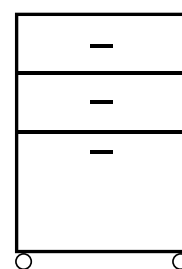

- 2 drawer
- 1 file drawer

- 600mm deep
- 25mm carcus & shelves
- 18mm doors & solid backs
- 50x50x80mm high steel square feet
- Double file drawer with heavy duty drawer system
- 16mm base
- soft close mechanism
- capacity up to 40kg per drawer

Add locks if required



837 CREDENZAS - ALL 725H

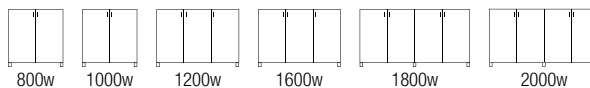

838 "A" UNITS - ALL 860H

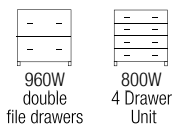
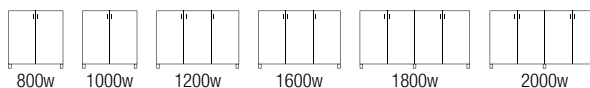

This is a flexible storage system that will mix and match to suit any office or home. Modular units that are all the same size that fit together to make a flexible practical and attractive environment.

Specifications

- 2000h x 800w x 400d
- 25mm Carcass & shelves
- 18mm drawer fronts and doors
- Melteca matching backs
- 50x50x80mm high steel square feet

Add locks if required

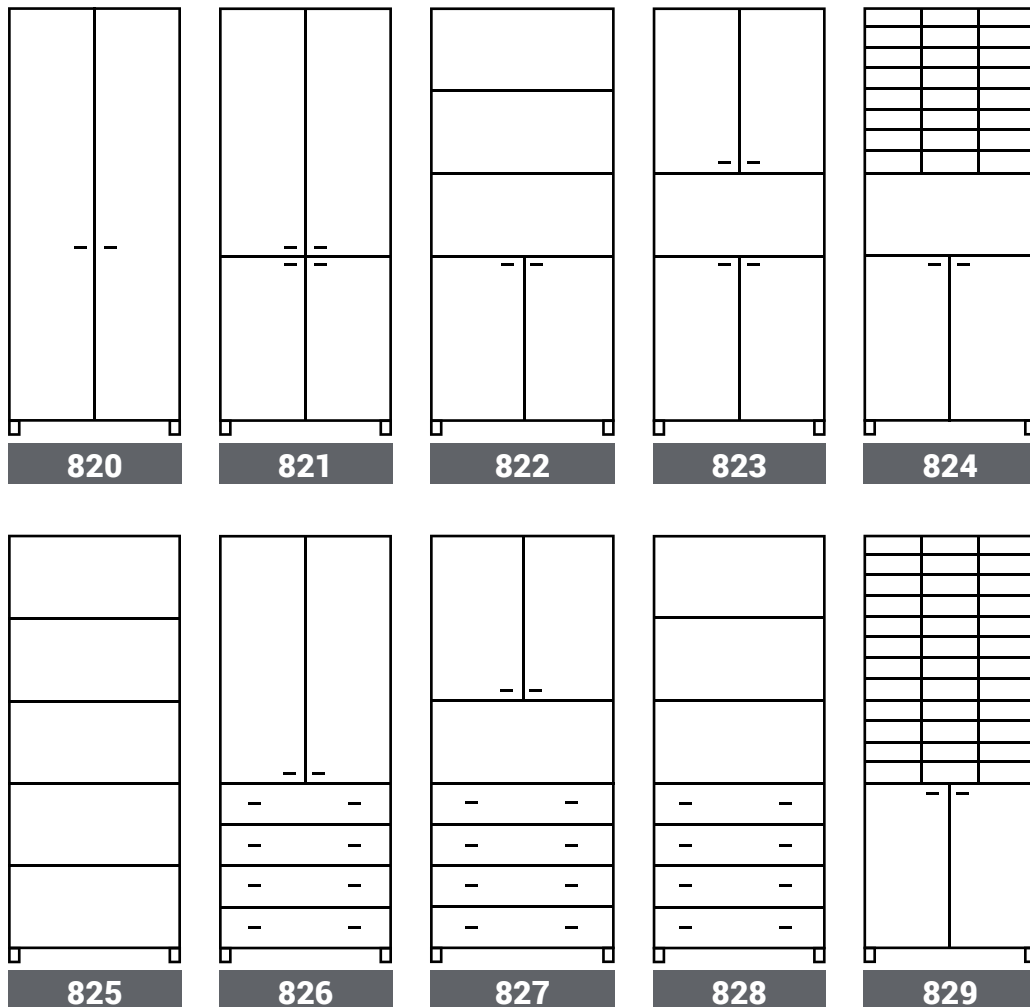

All units 2000 high x 800 wide x 400 deep

This is a flexible storage system that will mix and match to suit any office or home. Modular units that are all the same size that fit together to make a flexible practical and attractive environment.

Specifications

- 2000h x 800w x 600d
- 25mm Carcass & shelves
- 18mm drawer fronts and doors
- Melteca matching backs
- 50x50x80mm high steel square feet

Add locks if required

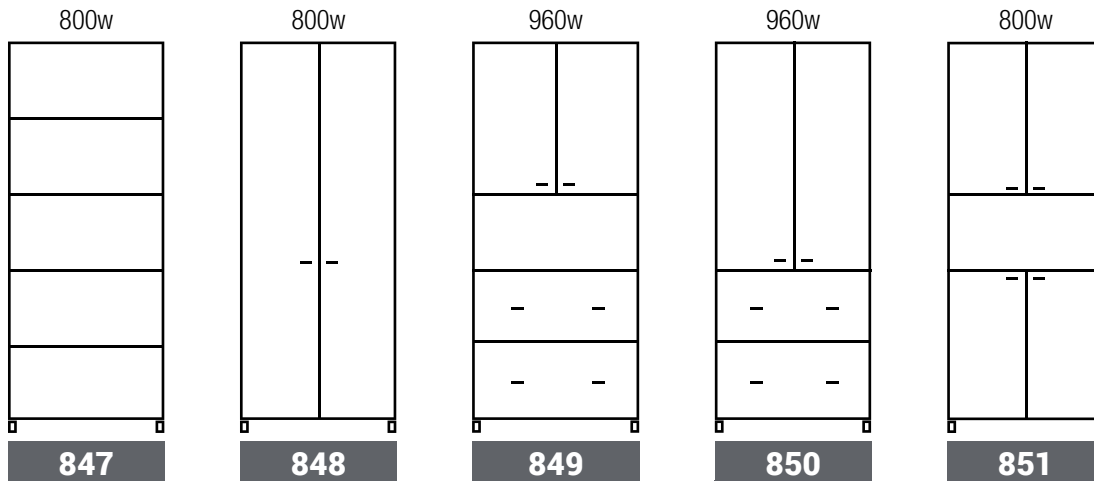

All units 2000mm high x 600mm deep



HETTICH HINGES



- We use Hettich sensys hinges on all our iQuad office furniture
- All smooth action "soft close" so the doors cannot slam shut



MODULAR UNITS

550 MOBY UNITS

• 490W x 490D • All 18mm Melteca • Mobile • Heavy duty drawers with 12mm white bases • Option to add ganglock

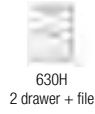

630H
2 drawer + file

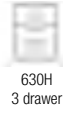

630H
3 drawer

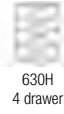

630H
4 drawer



700H
Double file

551 BOOKCASES

• 800W x 300D • All 25mm • plinth base • adjustable shelves (extra shelves available) • standard 4mm white back

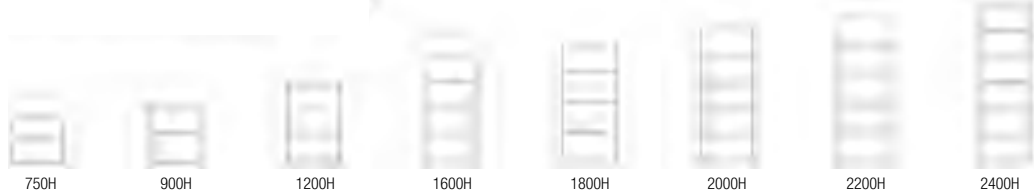

750H

900H

1200H

1600H

1800H

2000H

2200H

2400H

553 CUPBOARDS

• 800W x 400D • 25mm carcass • 18mm doors • adjustable shelves (extra shelves available) • plinth base
• standard 4mm white back • Optional locks



1200H
2 shelves



1800H
4 shelves



2000H
4 shelves



2200H
4 shelves



2400H
5 shelves

554 CREDENZAS

• 725H x 500D • 25mm carcass • 18mm doors • complete with 1 adjustable shelf • plinth base
• standard 4mm white back • optional locks



900W

1000W

1200W

1500W

1800W

2000W

555 A UNITS

• 900H x 500D • 25mm carcass • 18mm doors • complete with 1 adjustable shelf • plinth base
• standard 4mm white back • optional locks



900W

1000W

1200W

1500W

1800W

2000W

558 WALLMOUNTED BOOKCASES

• 900H x 300D • 25mm carcass & shelves
• solid white 18mm backs



900W



1200W



1600W



1800W

559 WALLMOUNTED CUPBOARDS

• 900H x 320D • 25mm carcass & shelves
• 18mm doors • Solid 18mm white backs



900W



1200W



1600W



1800W

560 WALL UNITS

• 2000H x 300D hutch x 500D credenza • 25mm carcass • 18mm doors • standard 4mm white back • Optional locks

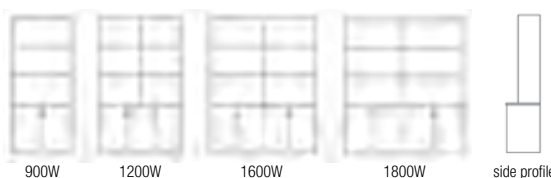

900W

1200W

1600W

1800W

side profile

OFFICE FURNITURE



Modular Units

CONFERENCE TABLES

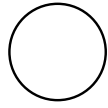

Round

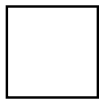

Square

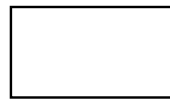

Rectangle



Capsule

802 iQuad TABLES



800 x 800	2200 x 800
1200 x 800	2400 x 800
1600 x 800	1200 x 1200
1800 x 800	1200 x 1800
2000 x 800	1200 x 2400

Top Options
 Square
 Rectangle
 Capsule
 Barrell
 D End

- 25mm Melteca tops with square corners
- 50mm square legs with 50x25 heavy duty rails
- Powdercoated frame
- All 725mm high

803 iQuad CONFERENCE TABLES



1200 x 1200
 1200 x 1800
 D Table 1200 x 800

Top Options
 Square
 Rectangle
 D Table

- 25mm Melteca tops with square corners
- 50mm square legs with 50x25 heavy duty rails
- Powdercoated frame
- All 725mm high

642 D-END BOARDROOM TABLE



1800 x 1000	'D' 1200 x 800
1800 x 1200	1200 x 1200
2000 x 1000	1800 x 1200
2000 x 1200	
2400 x 1200	

- All 25mm Melteca tops and bases
- Also available as a Capsule Top
- All 725mm high

852 iQuad + TABLES



Rectangle
 1800 x 800
 2000 x 1000
 2400 x 1200

Top Options
 Rectangle
 Capsule
 Barrell
 D End

- 25mm Melteca tops
- 50 x 50mm & 50 x 25mm heavy duty frame
- Powdercoated frame
- All 725mm high



Barrel



D-End



D-Table - 3 section



D-Table

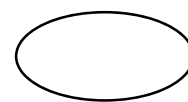

Oval

853 ORION TABLES



Round

900
1000
1200

Rectangle (2 bases)

1800 x 800
2000 x 1000
2400 x 1200

Top Options

Round
Rectangle
Capsule
Barrell
D-End
Oval

- 25mm Melteca tops
- Stainless steel base
- All 750mm high

854 PAVO



Square

800 x 800
900 x 900
1000 x 1000

Rectangle (2 bases)

1800 x 800
2000 x 1000
2400 x 1200

Top Options

Square
Rectangle
Capsule
Barrell
D-End
Oval

- 25mm Melteca tops
- Stainless steel base
- All 750mm high

635 CROSS BASE TABLES



- Round table on a cross base
- 800mm
- 900mm
- 1000mm
- 1100mm
- 1200mm
- 25mm Melteca top & base
- Also available with a curved base
- All 725mm high

930 TEAM FLIP TABLES



Standard Colours



White



Silver



Nordic Maple



Atlantic Oak

Standard Sizes

1400 x 700
1600 x 800
1800 x 900

- Standard colours - White, Silver, Atlantic Oak & Nordic Maple
- Frames - Powder coated silver, black, white or Chrome
- Strong, stable steel frame is rock solid
- Very durable, one handed flip mechanism - simply pull & tilt
- 25mm Melteca top with 2mm PVC edge
- 70mm locking castors - large wheels make these tables easy to move

762 PAVO & ORION BAR LEANERS



A

A Pavo square base with square top

600 x 600

700 x 700

800 x 800

B Orion Bar Leaner with Round Top

600 diameter

700 diameter

- Overall height 1085mm
- 304 brushed stainless steel bases
- Adjustable feet for uneven surfaces
- 25mm Melteca tops
- Formica tops P.O.A.



B

761 STRONGBOW LEANER

- 1020mm high
- 600 x 600 square
- 1200 x 500 rectangular
- 800 diameter round
- With or without shelf
- 32mm round steel frame

Option for tops

- 25mm Melteca
- Formica P.O.A.



801 iQuad COFFEE TABLE



600 x 600
800 x 600
1200 x 600

- 25mm tops with square corners
- 50x50mm steel frame
- All 450mm high • Can be made to size

857 ORION ROUND COFFEE TABLES



600 diameter x 465H
900 diameter x 465H

- 25mm Melteca tops
- Stainless steel base

859 iQuad CUBE COFFEE TABLE



600 x 600 x 450H

- 25mm Melteca
- iQuad feet
- Can be made to size

858 PAVO SQUARE COFFEE TABLE



600 x 600 x 465H
800 x 800 x 465H
1000 x 1000 x 465H

- 25mm Melteca tops
- Stainless steel base

375 iQuad TRI-CUBE COFFEE TABLE



900L x 400D x 400H

- 25mm Melteca with iQuad feet
- Can be made to size

374 TRI-CUBE COFFEE TABLE



900L x 400D x 400H

- 25mm Melteca
- Can be made to size

All Europlan cabinets available on request

• Pigeon holes • Shelving • Stationery cabinets • Eurotilt filing • Tambour

720 FORTE FILING CABINETS - COMMERCIAL GRADE

Dimensions

- 2 Drawer - 505W x 619D x 720H mm
- 3 Drawer - 505W x 619D x 1018H mm
- 4 Drawer - 505W x 619D x 1311H mm
- Available in standard powder coat colours
- Fully powder coated
- Lockable
- 45kg weight per drawer
- Holds an average of 55 files per drawer
- Lifetime Warranty
- NZ Made - available in 8 colours



721 PROCEED FILING CABINETS - COMMERCIAL GRADE

Dimensions

- 2 Drawer - 465W x 620D x 720H mm
- 3 Drawer - 465W x 620D x 1015H mm
- 4 Drawer - 465W x 620D x 1320H mm
- Fully Powder Coated
- Lockable
- 35kg weight capacity per drawer
- 10 Year Warranty
- Available in 3 colours:
Black, Grey and Dusk Blue



723 STORAGE CUPBOARDS

- Fully Powder Coated
- Lockable
- 10 Year Warranty
- Available in 4 colours:
Black, Dusk Blue, Stone Grey or Ice White

Sizes and Dimensions

- 900W x 500D x 1000H mm
with 2 adjustable shelves
- 900W x 500D x 1800H mm
with 3 adjustable shelves

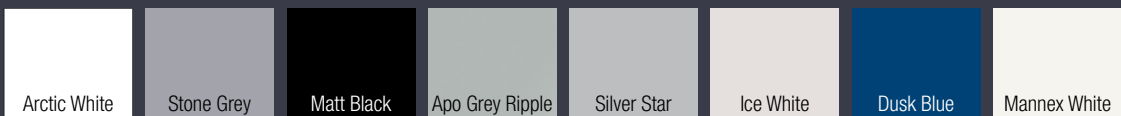

728 LOCKERS



All 1800 High x 450 Deep
300 or 375 Wide

Available in 8 colours
(see previous page)

Europlan Lockers are constructed from steel with a powder coat finish. Lockers are often installed in factories, warehouses, sports centres, schools, tertiary facilities and offices.

- Standard Lockers available in widths of 300mm and 375mm
- Door options range from 1 to 4 door lockers
- Available in Standard Powder coat Colours
- Fully lockable - 3 locking options of Camlock, Hasp & Staple and D Loop
- Lockers supplied either built - up to a maximum bank of four or completely knocked down (CKD) and assembled on site
- Square vents for ventilation
- Master key option available
- All Europlan lockers have lifetime warranty on all parts and workmanship

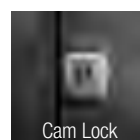
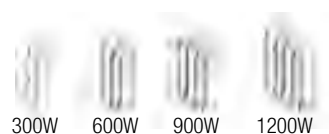

Cam Lock

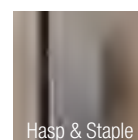

Hasp & Staple

724 PROCEED STEEL LOCKERS



All 1800 High x 450 Deep
300 or 375 Wide

Colour - Stone Grey only

The Proceed Locker range is available in widths of 300mm and 375mm

- Fully powder coated
- Ventilation slots
- Available with either a Camlock or Latchlock
- 10 Year Warranty

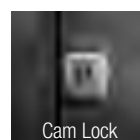

Cam Lock

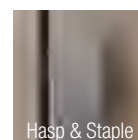

Hasp & Staple

WHITEBOARDS, PINBOARDS & PARTITIONS ETC



CONTENTS

Autex.....	116
Whiteboards & Pinboards	117-120
Partitions & Screens	121-123
Stages & Lecturns	124
Lundia Shelving	125-126
Glass Cabinets	127



AUTEX

Interior Acoustics

PEEL 'N' STICK TILES COLOUR RANGE



Atlantis

Blazing Red



Citrus

Civic



Electric Blue

Granny Smith

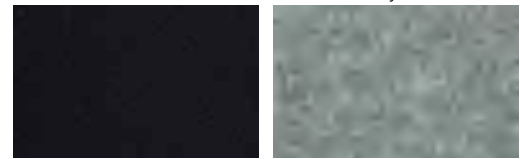

Noir

Silver

Reduce reverberated noise and add a vibrant feature to your environment with Composition® Peel'n'Stick Tiles. An acoustic and decorative self-adhesive wall fabric; Composition® Peel'n'Stick Tiles are the simple choice for managing echo and creating a durable interior solution.

Key Features

- Made from 100% polyester fibre
- Available in 8 fashionable colours
- All the features and benefits of Composition® plus the added "easy DIY use" of a self-adhesive backing
- Fabric Weight: Typically 1600gsm
- Product Format: Tile size: 600mm x 600mm*
- Easy to install (DIY)

Applications

- An acoustic and pinboard surface with hook-and-loop capabilities
- Display, privacy and noise control for modular room divider
- Decorative and functional acoustic wallcovering for educational, retail and commercial interiors

Product Specifications

- Tile size: 600mm x 600mm
- Tiles per pack: 12
- Coverage: 4.32m³



8 standard colours

All Composition® colours are available in orders of 10 boxes or more

366 COMPOSITION® & VERTIFACE® COLOURS

* Composition® also available in standard roll: 25m x 1.22m

Cut lengths available
Available in 38 colours



350 PORCELAIN WHITEBOARDS

These strong and durable magnet receptive whiteboards will withstand many years of frequent use.

The nonporous surface erases clean every time and won't stain, scratch or 'ghost'.

Features

- Anodized aluminium frame
- Concealed wall fixings included
- Aluminium pen shelf included
- Magnetic receptive surface
- Forever Surface Guarantee*

Standard Sizes

- Frame depth: 20mm
- Pen shelf depth: 55mm

* *Boyd Visuals porcelain whiteboards have a Forever surface guarantee, subject to the product being used for its designed purpose.*

** *Finished size including the frame*

Customised Options

- Custom manufactured sizes
- Custom porcelain whiteboards are available with white or grey surface
- Laser engraving & signage



A porcelain whiteboard is the best choice if your whiteboard will be used regularly. Ideal for education, commercial, and other medium to high use applications.

Board Size** (mm)	Pen Shelf Length (mm)
600 x 900	375
900 x 900	375
900 x 1200	375
900 x 1500	750
1200 x 1200	750
1200 x 1500	750
1200 x 1800	750
1200 x 2400	750
1215 x 3000	750
1215 x 3600	750

351 LACQUERED STEEL WHITEBOARDS

These lacquered steel (acrylic) magnet receptive whiteboards are ideal for general use. The write on - wipe off surface is easy to clean and resists staining or 'ghosting'.

Features

- Anodized aluminium frame
- Concealed wall fixings included
- Aluminium pen shelf included
- Magnetic receptive surface
- 5 Year Surface Guarantee*

Standard Sizes

- Frame depth: 18mm
- Pen shelf depth: 55mm

* *Boyd Visuals lacquered/acrylic whiteboards have a Five Year surface guarantee, subject to the product being used for its designed purpose.*

** *Finished size including the frame*



It is better to use porcelain whiteboards when in high use environments

Board Size** (mm)	Pen Shelf Length (mm)
600 x 900	375
900 x 900	375
900 x 1200	375
1200 x 1200	750
1200 x 1500	750
1200 x 1800	750
1200 x 2400	750

353 PORCELAIN PROJECTION BOARD

Ideal for spaces that are exposed to excessive ambient light, Porcelain Projection Board is scientifically engineered to reduce glare.

Teaching and presentation methods have evolved. More multimedia, projection and interactive content is being incorporated into classrooms and corporate meeting spaces worldwide.

This advancement in technology has led to tension between glare reduction and dry erasability. As a result, students and co-workers are experiencing shorter attention spans, visual fatigue and reduced knowledge transfer.

Porcelain Projection Board addresses that problem with a surface that both enhances the projection and write-erasability.

Features/Benefits

- Magnetic Receptive
- Forever Surface Guarantee
- Optimized for Projection
- Reduced "Hot Spots"
- Clear Vibrant Images

Sizes

Porcelain Projection Boards can be custom made to the size you require.

Board Size** (mm)	Pen Shelf Length (mm)
1220 x 1500	750
1220 x 1800	750
1220 x 2400	750
1220 x 3000	750
1220 x 3600	750

Porcelain Projection Board is optimized for projection, writing and erasing - It meets the growing needs of today's students and workers.



STANDARD WHITEBOARD SURFACE



Glare & hot spot from projection or sunlight

PORCELAIN PROJECTION BOARD



Reduced glare & hot spot from projection or sunlight

361 MOBILE PIVOTING WHITEBOARDS

Available with either porcelain or lacquered steel surface. The robust steel frame is on lockable 50mm castor's for ease of moving and securing.

Features

- Double-sided whiteboard
- Lockable castor's for stability
- Magnetic receptive surface

Porcelain Sizes

Board Size** (mm)	Overall Size WxHxD (mm)
1200 x 900	1285 x 1750 x 550
1200 x 1200	1285 x 2050 x 550
1500 x 1200	1585 x 2050 x 550
1800 x 1200	1885 x 2050 x 550



Lacquered Steel Sizes

Board Size** (mm)	Overall Size WxHxD (mm)
600 x 900	685 x 1750 x 550
1200 x 900	1285 x 1750 x 550
1200 x 1200	1285 x 2050 x 550
1500 x 1200	1585 x 2050 x 550
1800 x 1200	1885 x 2050 x 550



918 MOBILE 'FIXED' WHITEBOARDS & PINBOARDS

Robust steel legs (with 50mm castor's) are attached to whiteboards or pinboards so that they can be used for displays or as dividers.

Available in a range of sizes, mobile whiteboards and pinboards satisfy a wide variety of requirements and can be used as room dividers or partitions.

The pinboards are available in a range of fabric colours or customer supplied fabric.

Board Size** (mm)	Overall Size WxHxD (mm)
1200 x 1200	1250 x 1800 x 530
1200 x 1500	1250 x 1800 x 530
1200 x 1700	1250 x 1800 x 530



344 FRAMED PINBOARDS

Pinboards are one of the easiest ways to display and communicate information. These aluminium framed pinboards are available in a range of fabrics and surfaces to suit your interior.

Features

- Natural anodized aluminium frame with matching plastic corners
- Concealed wall fixings included

Options

- Clip-on shelf
- Custom manufactured sizes
- Customer specified fabric

Board Size**
(mm)

Rapid-dispatch cork or fabric

- 600 x 900 - Cork, Blue, Grey & Black
- 900 x 900 - Cork, Blue & Grey
- 900 x 1200 - Cork, Blue, Grey & Black
- 1200 x 1200 - Cork, Blue & Grey
- 1200 x 1500 - Cork, Blue, Grey & Black
- 1200 x 1800 - Cork, Blue, Grey & Black

Rapid-dispatch velcro

- 600 x 900 - Grey
- 900 x 1200 - Grey



352 ALUMINIUM FRAMED & WRAPPED EDGED PINBOARDS

Pinboards are one of the easiest ways to display and communicate information. These aluminium framed or wrapped edge pinboards are available in a range of fabrics and surfaces to suit your interior.

Features

- Natural anodized aluminium frame with matching plastic corners
- Concealed wall fixings included

Options

- Clip-on shelf
- Custom manufactured sizes
- Customer specified fabric
- Aluminium frame with Quantum or Vetiface fabric
- Wrapped panels with Quantum or Vertiface fabric

Board Size**
(mm)

- 600 x 900
- 900 x 900
- 900 x 1200
- 1200 x 1200
- 1200 x 1500
- 1200 x 1800
- 1200 x 2400
- 1200 x 3000
- 1200 x 3600



358 WET ENVIRONMENT WHITEBOARDS

Designed specifically for use in damp or wet environments these boards utilize a different construction technique while still maintaining the full functionality of our standard Porcelain Whiteboards.

Features

- Aluminium Frame with matching pen shelf
- Concealed wall fixings included
- Magnetic receptive surface
- Secure & easy to install
- Forever Surface Guarantee*

Board Size (mm)	Pen Shelf Length (mm)
1220 x 1500	750
1220 x 1800	750
1220 x 2400	750

Sizes

Water Resistant Whiteboards are custom made to the size you require.

* Boyd Visuals porcelain whiteboards have a Forever surface guarantee, subject to the product being used for its designed purpose.



935 GLASS BOARDS

These strong and durable magnet receptive glassboards will withstand many years of frequent use, while still looking great.

Features

- 4mm Toughened Safety Glass
- 4 x Super Strong magnets
- Acrylic pen tray provided

Board Size (mm)	Colour
600 x 900	White
900 x 1200	White
900 x 1500	White
1200 x 1800	White
1200 x 2100	White
600 x 900	Black
900 x 1200	Black
1200 x 1800	Black

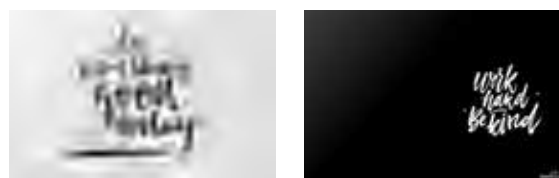

356 PRINTING ON WHITEBOARDS

Boyd visuals can laser etch any design onto a whiteboard including maps, plans, scoreboards, logos, farm boundaries etc.

Note

Laser etching creates black images only (Colour can be added with vinyl).

Board Size** (mm)

600 x 900
900 x 900
900 x 1200
900 x 1500
1200 x 1200
1200 x 1500
1200 x 1800
1200 x 2400



FOREVER SURFACE GUARANTEE



MEDIUM HEAVY USE



CUSTOMISED OPTIONS

355 YEAR PLANNERS

Our Year, School Year and Term Planners give a visual overview of plans and commitments yet allow flexibility when things change.

Features

- Laser etched porcelain-on-steel surface
- Anodized aluminium frame
- Concealed wall fixings included
- Aluminium pen shelf
- Magnetic receptive surface
- Forever Surface Guarantee*

Options

- Custom manufactured sizes
- Custom designs - e.g. maps, plans, scoreboards, logos
- Custom signage

* Boyd Visuals porcelain whiteboards have a Forever surface guarantee, subject to the product being used for its designed purpose.



FOREVER SURFACE GUARANTEE



MEDIUM HEAVY USE



CUSTOMISED OPTIONS



MAGNET RECEPTIVE

Board Size** (mm)

'Square' Sizes (mm)

Year Planner	
900 x 1200	35 x 68
1200 x 1500	45 x 68
1200 x 1800	55 x 68
School Year Planner	
900 x 1200	275 x 69
1200 x 1500	350 x 94
1200 x 1800	425 x 94
Term Year Planner	
900 x 1200	180 x 70
1200 x 1500	230 x 95
1200 x 1800	280 x 95

357 STAFF INDICATOR BOARDS

Available in three sizes to suit your organisation. They can be removable for emergency evacuations.

Features

- Screen printed lacquered steel surface
- Anodized aluminium frame
- Aluminium pen shelf and all magnets included
- Concealed wall fixings included
- Magnetic receptive surface
- 5 Year Surface Guarantee*

* Boyd Visuals lacquered steel whiteboards have a Five Year surface guarantee, subject to the product being used for its designed purpose.

Board Size (mm)

Names

450 x 600	12
600 x 600	17
600 x 900	27



5 YEAR SURFACE GUARANTEE



MAGNET RECEPTIVE



Keep everyone informed of staff whereabouts with a Staff Indicator Board.

919 FREE STANDING PARTITIONS

Light, stable, pinnable and effective - The partitions can be easily linked using the clever integrated system. No additional fittings are required to attach one partition to another.

- Frosted, Charcoal and Blue, partitions are designed to be simple, strong and effective
- Customise your space - the panels can be inter-connected very simply (everything you require is supplied in just one package)
- Each panel can swing through 360 degrees for ease of storage and creating that unique space
- The exclusive inter-locking system ensures the partitions are stable and robust
- Boyd Visuals Free Standing Partitions are supplied complete with feet and castor's that rotate under the frame when not required
- All fabric (Blue & Charcoal) panels are pinnable
- 3 year Guarantee

Height (mm)	Length (mm)
1500	900
1800	900

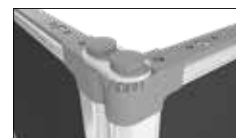
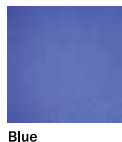
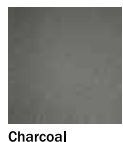

920 DESK MOUNTED PARTITIONS

Boyd Visuals Partitions are contemporary, effective and easy to use - no extra parts required. They are a new style of office & room divider, available for prompt delivery in 3 standard colours and 4 standard widths.

- Frosted, Charcoal and Blue, partitions are designed to be simple, strong and effective
- Panels can be connected to the desk very simply - everything required to install is supplied in one package
- All fabric (Blue & Charcoal) panels are pinnable.
- 3 year Guarantee

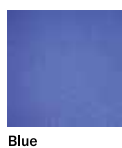
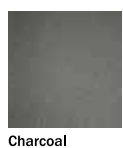

Height (mm)	Length (mm)
450	1460
450	1760

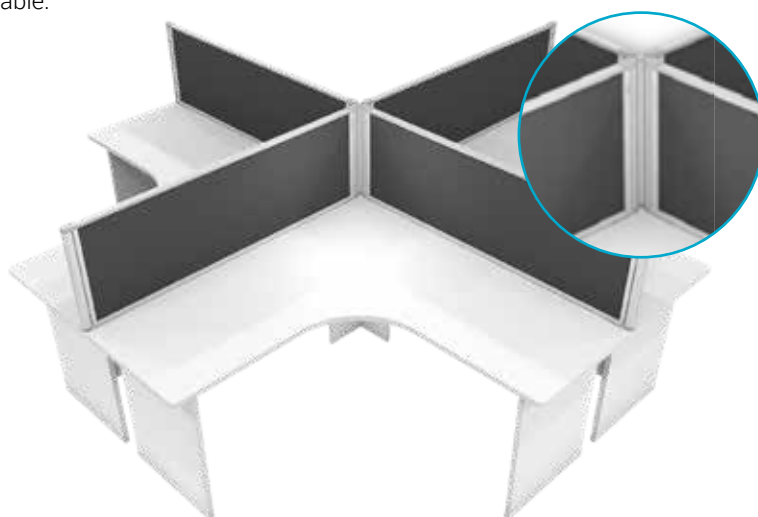

90mm Clamp to fit on desks that have a steel frame



45mm Offset Clamp to miss the leg end

Please specify clamps required



563 BOYDS SCREENS



3
YEAR
GUARANTEE

Height (mm)	Length (mm)	Colour
340	1180	Lime Green
340	1180	Charcoal
340	1380	Lime Green
340	1380	Charcoal

Desks screens are the ideal solution where extra privacy is needed. A contemporary design made with PET to be lightweight yet very robust for everyday office use. They are simple to install with everything needed coming in one box. Available in Lime Green and Charcoal with clamps that fit desks up to 25mm thick.

309 ROOM DIVIDER



1200L x 1200H

- Double sided pinboard
- 35mm X 19mm rectangular steel frame with powdercoated finish
- Twin wheel castors (2 locking) or glides
- Can be made to size
- Available in Vertiface or Quantum
- Available in other fabrics on request

740 CONTOUR SCREEN PANELS



A simple privacy panel which easily clamps onto most desking systems.

- Lightweight panel with aesthetic shape
- Pinning capacity, panels will accept push-type pins
- Reversible left or right fitting
- Rounded corners with protective PVC edging
- Standard Quantum fabric - other fabrics available upon request

- 1200mm wide x 600/300mm high
- 1500mm wide x 600/300mm high
- 1600mm wide x 600/300mm high
- 1800mm wide x 600/300mm high
- 100mm hangs under the desk

750 QUADSCAPE - CLIP ON PANEL



Simple cast alloy clamp system to suit most desks and tables

- Fast installation
- Silver aluminium capping
- Simple reconfiguration
- Four standard sizes • Custom panel sizes
- Standard Quantum fabric - other fabrics available upon request

- 1200mm wide x 600mm high
- 1500mm wide x 600mm high
- 1600mm wide x 600mm high
- 1800mm wide x 600mm high
- 100mm hangs under the desk

MODULINK VELCRO CONNECTION SCREEN PANELS

Specifications

- Aluminium capping & corner posts
- Ultra simple velcro connection
- Easy pinning composite panel
- Fast installation and reconfiguration
- Part glazed option on request
- All Quantum colours available
- Other fabrics available on request
- Modular and custom panel dimensions



Screen Heights

- 741** 1200 - for some sitting communication
- 742** 1500 - for sitting privacy
- 743** 1800 - for standing privacy

Screen Widths

600, 800, 900, 1000, 1200, 1400, 1500, 1600, 1800

- Panels can also be made to your specifications

Other fabrics available on request

- Metal trim is natural silver anodised
- Back is velcro
- Option to add perspex panels
- Option to add ducting & plugs/data
- Finishes - Polypropylene fabric is standard. (Quantum)

MODULINK COMPONENTS, EXTRAS AND OPTIONS

746 2 WAY CORNER POST



1200H
1500H
1800H

745 3 WAY CORNER POST

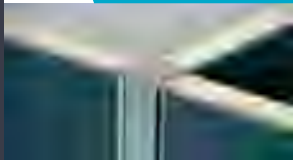

1200H
1500H
1800H

913 4 WAY CORNER POST



1200H
1500H
1800H

744 PLAIN END



1200H
1500H
1800H

922 HOOK OVER SHELF



- Hook over a screen

749 JOIN BRACE

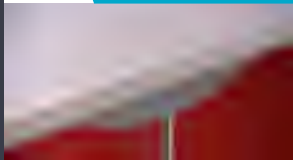

- The join brace bracket can also be used as a wall fix and as an adaptor to other screen systems

747 SUPPORT FOOT



748 MOBILE FOOT



446 FOLDAWAY STAGE

- Ideal for clubs, hotels, schools, halls & libraries.
- Can be opened up in any direction and is connected by locking straps
- Easy to assemble and pack up
- All staging is supplied complete with black carpet and black powdercoating
- Other colours available on request

Overall size of each module 2400 x 1200

Each stage comprises of

- One folding frame
- 2 support struts
- 2 1200 x 1200 tops
- 1 strap

Heights

- 300mm (frame weight 25kg)
- 600mm (frame weight 32kg)
- 900mm (frame weight 63kg)

Stairs - available for 600mm and 900mm

Infills - Available per section

Trolleys available - will hold up to 5 sets

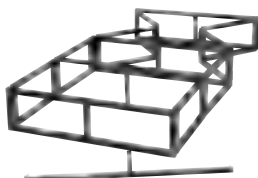

373 LECTURN STAND



- 1100H x 600W x 450D
- 32mm steel uprights
 - Oval curved foot
 - Melteca board

Optional

- Add shelf

561 ADJUSTABLE LECTURN



Top Tilts from:
Back 1250 - 1090
Front 970 - 1240
600W x 400D

- Shelves are 400W x 300D
- Lecturn with 2 shelves and a height adjustable top
- Powder coated steel fascia
- Beech top & shelves

738 LUNDIA MOBILE STORAGE - MANUAL SYSTEM

739 LUNDIA MOBILE STORAGE - ROTODRIVE SYSTEM



Environmental, economical & space saving. Certified by Environmental Choice New Zealand & EnviroSpec Verified

Lundia mobile storage systems are a practical, space-saving and adjustable storage solution that's ideal for a range of environments. From educational facilities, government departments, commercial fit-outs, hospitals & libraries, Lundia mobile shelving can be tailored to suit any space, décor, design and storage need. Lundia mobile units can be customised to maximise available space and optimise your floor plan.

Lundia mobile storage systems are built from plantation grown, sustainable harvested radiata pine, with the option of eco-friendly lacquer alternatives.

This means they're not only space saving and practical, they're also an environmentally responsible storage solution.

Specifying Lundia mobile shelving units in natural timber finish with Melteca ends is a green star choice.

When you specify these products and finishes for your interior fit-out projects or Educational fit-out projects they contribute towards a green star rating.

SHELF DEPTHS FOR FILING REQUIREMENTS

Eastlight Files	292mm deep shelf – check height of file ie: foolscap or A4 for shelf spacing
Box files	Standing end-on-end 292mm shelf depth Spacing as above, check A4 or foolscap
Box files Foolscap	385H 250D 85W
Box files A4	340H 250D 85W
Foolscap Lever Arch file	350H 280D 85W
A4 Lever Arch file	320H 285D 85W

Upright Heights	Shelf Lengths	Shelf Depths
1829mm	600mm	235mm
2100mm	800mm	292mm
2400mm	900mm	381mm
	1000mm	457mm
	1200mm	610mm

Lever Arch Box Files Laying on spine or flat 381mm shelf depth. Required spacing between shelves depends on client's requirement and how many boxes high they stack when stored flat

Colour Coded Files 381mm shelf depth required Check spacing with file height (usually 2100mm high with 8 shelves and storage levels 25mm drilled uprights) but we strongly recommend checking sizes

School Box Journals Usually 210mm high 8 shelves, 7 storage levels 25mm drilled uprights 292mm depth is usually ok, but we strongly recommend checking sizes

Paper sizes

A4	= 210mm x 297mm
A3	= 297mm x 420mm
A2	= 420mm x 594mm
A1	= 594mm x 841mm



TECHNICAL INFORMATION

- Manual or Rotadrive (mechanically assisted) carriage options
- No nuts and bolts
- Fully adjustable and relocatable
- Each system is created to your space & design requirements
- All shelves are smooth & flat on both sides with no downturn lips to obstruct items being removed
- Shelves vertically adjustable at 50mm or optional 25mm increments
- Mobile systems move silently – our timber absorbs noise & will not rattle
- Mobiles have a tracking system under each upright for greater ease of movement & load spreading
- Solid timber construction protects files by regularity humidity, absorbing moisture & no conduction heat or electricity
- The wheels have sealed bearings that require no maintenance
- A shelf will carry up to 200kg with a maximum of 580kg per single shelving bay
- A manually operated unit will carry 2500kg per carriage
- New low profile track - 17mm
- Exterior face panels can be customised with a wide range of materials including: Melteca or timber veneer, paint finish or UV clear lacquer, mirror, fabric, wallpaper, perspex, glass and company branding.

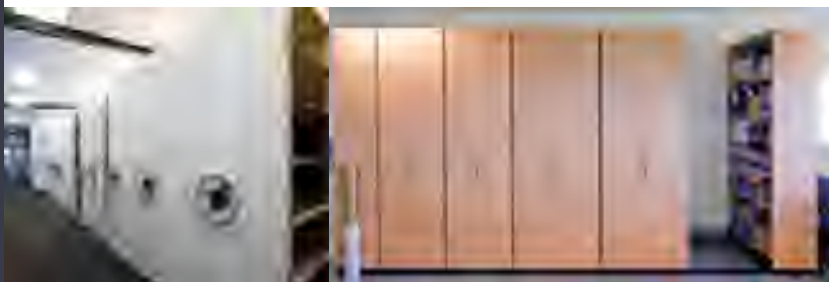

739 ROTODRIVE SYSTEM

738 MANUAL SYSTEM

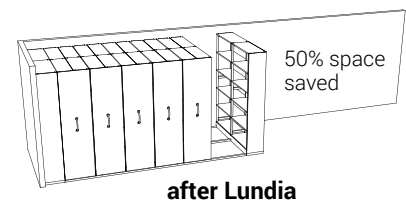
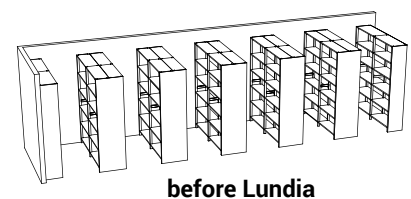



Warm up the look of your library using the Lundia wooden shelving systems

Options available

- Lacquered timber
- Coloured, painted or stained
- Flat & display shelves available
- Natural wood finish

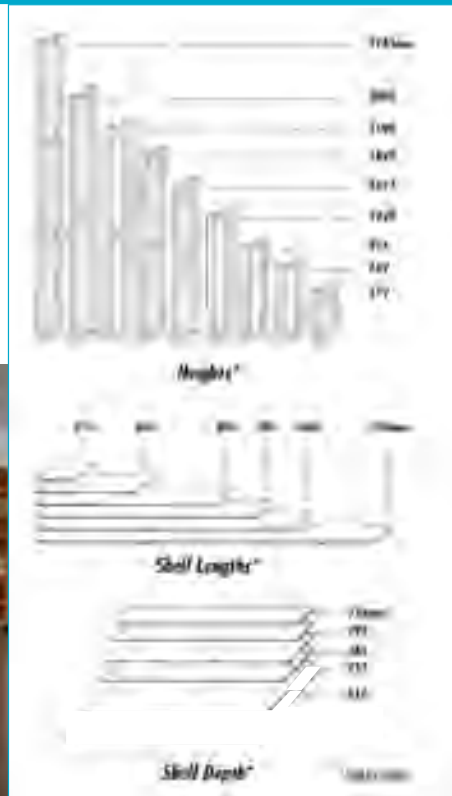

Lundia Shelf Heights, Lengths and Depths to Solve Every Space Need

Standard sizes shown below can be assembled in any combination to make up the unit you require.

Clearance Between Upright Frames:

The shelf length less 30mm is available for accessing stored items.

Overall Length of Shelving Unit:

Open upright type = shelf lengths + 30mm added once.

Panelled upright type = shelf lengths + 30mm added once + 5mm for each panelled upright.

The Benefits of Choosing a Lundia Shelving Solution

- No nuts and bolts required
- Lundia is quick and easy to install
- Shelves are adjustable at 50mm or 25mm centres
- All Lundia shelving products are easily installed, fully adjustable, demountable and relocatable
- Sort out all your resources
- Sort out your art room
- Store all the coloured paper effectively without waste
- Store all black & white paper
- Store all the paint etc so its easy to find & return



This range is suitable for trophy cabinets, display cases and shop counters.

There are options available so using the check list you can design your cabinet to suit. Please note that there are more options available on request

Check list

Choose the style that you require

- Nova top
- Standard top
- Frame top

Sizes

- 1800h x 1000w x 500d / 400d
- 1800h x 500w x 500d / 600w x 400d
- 900h x 2000w x 500d
- 900h x 1000w x 500d
- Other sizes available on request

Do you require?

- Down lights – (Frame top only)
- Spot lights

Glass and sides

- Sides and fronts are all priced with safety glass
- Backs have standard glass unless specified otherwise
- Shelves are all 6mm standard glass

Doors

- Sliding locking doors
- Swing opening locking doors

Options

- Mirror back
- Melteca back

Colour

- Satin Anodized Aluminum
- Option to powder coat



Optional Tops



Nova Top



Standard Top



Frame Top

Optional Lights



Downlights



Spotlights

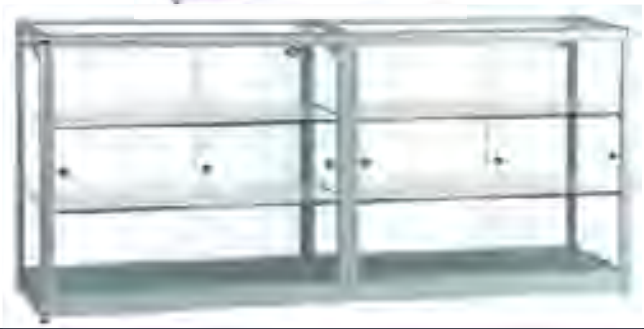

Quantum

- 100% Polypropylene
- Heavy Duty Commercial Fabric
- Upholstery & Screen Fabric

at work*
with
Instyle



Capri



Poppy



Lawn

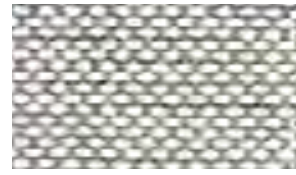

Gallery



Pebble Grey



Mineral Red



Hunter



Natural

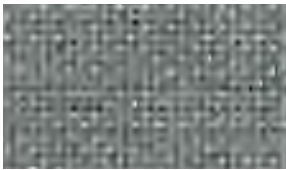

Gunsmoke



Claret



Storm



Ruby



Cornflower Blue



Riviera



Nebula



Navy



Venus



Stonewash



Black

BOND

Screen/Upholstery

- 100% Polyester
- Heavy Duty Commercial Fabric
- Upholstery & Screen Fabric

at work*
with
Instyle



Garnet



Snow



Smoke



Spring



Lemoncello



Linen



Navy



Royal



Leaf



Shark



Grey Haze



Jet

NOTE: PATTERNS ARE NOT TO SCALE

Please visit our website to see more fabric samples

Please note that colours pictured are as close to specification as the printing process will allow.

JAMES DUNLOP

- 58% PL, 36% PC, 6% VI
- Martindale 40,000 Rubs

Tapa Range



Aluminium



Aqua



Lime



Pumice

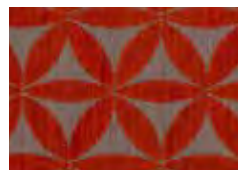

Tangelo

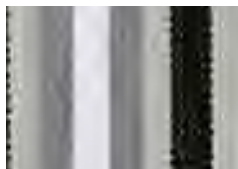

Stripe Aluminium



Stripe Aqua



Stripe Lime

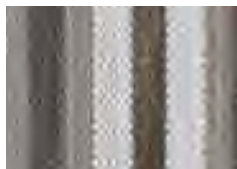

Stripe Pumice



Stripe Tangelo

JAMES DUNLOP

- Direction & Shard
- 59% CO, 41% PL
 - Martindale 45,000 Rubs
- Code & Template
- 56% PC, 32% PL, 12%CO
 - Martindale 45,000 Rubs

City Scope



Code Asphalt



Code Harbour



Direction Harbour

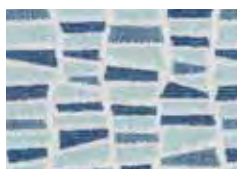

Shard Aqua

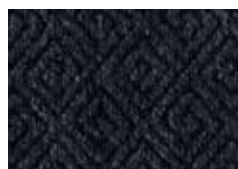

Template Harbour



Code Bitumen



Code Crossing

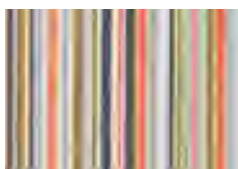

Direction Domain

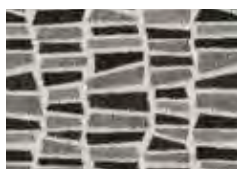

Shard Asphalt



Template Crossing



Code Lipstick



Direction Candy

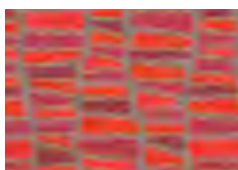

Shard Lipstick



Template Lipstick



Template Stop



Code Metro



Code Platform



Direction Metro

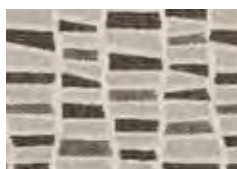

Shard Metro



Template Metro



Code Stop



Code Works



Direction Works

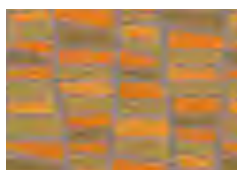

Shard Works



Template Works

NOTE: PATTERNS ARE NOT TO SCALE

Please visit our website to see more fabric samples

Please note that colours pictured are as close to specification as the printing process will allow.

High Performance

- Excellent durability
- Optimum washability
- Easy cleanability
- FibreGuard = fresh looking fabric

Stain Free Technology

- Tackle stains easily
- Remove ballpoint pen, coffee, red wine, ketchup, mud etc
- Low maintenance
- Child friendly
- Pet friendly

Cleaning instructions

1. Remove any remaining stain residue with flat utensil.
2. Apply water to the stain and blot using a white paper towel. Do NOT rub in a circular motion. Repeat the process until the stain residue is no longer visible on the paper towel.
3. Apply more water to the area for stubborn stains. A normal household soap may be used. Gently rub with a microfiber cloth. Use circular movements for best results. Repeat the process until completely removed. (when using soap, use intermittently)
4. Allow the fabric to dry naturally. Do not apply heat



Azure



Biscayne Earth



Cardozo Teal



Fairchild Marine



Ocean Drive Horizon



Bayfront Ink



Biscayne Metal



Cardozo Charcoal

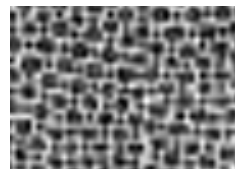

Coconut Grove Stone



Fairchild Slate



Daytona Denim



Lauderdale Lapis



Lucie Cobolt



Manalapan Arctic

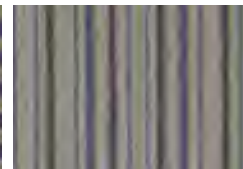

Oviedo Azure



Biscayne Emerald



Lauderdale Jade



Ocean Drive Forest

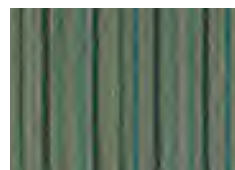

Oviedo Ocean



Palm Beach Turquoise



Biscayne Tropical



Lauderdale Lipstick



Lucie Magenta



Ocean Drive Daiquiri



Unicode Berry



Lucie Coin



Manalapan Ash



Oviedo Fog



Palm Beach Pewter



Sarasota Iron

NOTE: PATTERNS ARE NOT TO SCALE

Please visit our website to see more fabric samples

Please note that colours pictured are as close to specification as the printing process will allow.

Convoy



- 100% Polyester
- Martindale 100,000 Rubs



Beluga

Brick

Burgundy

Charcoal

Denim



Legion

Otter

Palm

Petrol

Poppy



Putty

Shark

Slate

Spruce

Terra

Centurion



- 100% Polyester
- Martindale 100,000 Rubs



Beaujolais

Beetle

Brick

Buff

Canyon



Cappuccino

Charcoal

Cream

Crystal

Curacao



Denim

Feather

Gargoyle

Linen

Magenta



Moss

Mushroom

Pine

Pineapple

Reef



Shadow

Shark

Slate

Sterling

Zinc

NOTE: PATTERNS ARE NOT TO SCALE

Please visit our website to see more fabric samples

Please note that colours pictured are as close to specification as the printing process will allow.

Octavia



- 61% Poly Acrylic
- 39% Polyester

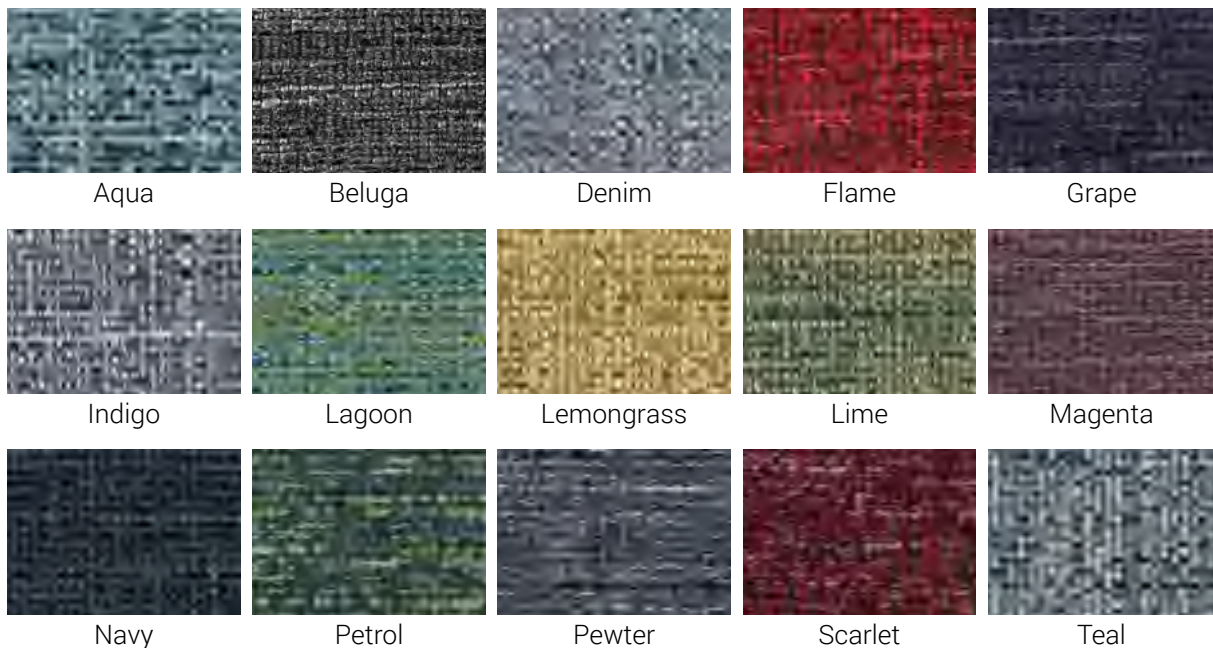

Pacifica Vinyl



- Martindale 50,000 Rubs



Pacifica vinyl is an Indoor/Outdoor FR Vinyl, high strength backing fabric with RESISTAIN finish.

Cleaning and care of vinyl

- To clean, wipe with soft sponge or cloth moistened in warm soapy water, then dry with a soft cloth
- Liquid spills should be blotted with a soft dry cloth.
- For other stains add a small amount of mild detergent.
- For Grease, Pen, Markers and Crayons, Isopropyl Alcohol is recommended for spot cleaning
- Prompt attention to cleaning will yield the best results

NOTE: PATTERNS ARE NOT TO SCALE

Please visit our website to see more fabric samples

Please note that colours pictured are as close to specification as the printing process will allow.

Kerri's Kolours



Memphis Blue



Memphis Red



Memphis Green



Energise



Juicy



Caribbean



Olympia Yellow



Storm

Birchwood Range



Snowdrift



Raw Birch Ply

Melteca Decorated Board is a versatile pre-decorated panel with a durable melamine surface on both sides. For interior use only, Melteca Decorated Board is available in a range of decors, on a choice of substrates, sizes & thicknesses.

Never use any of the following Abrasive cleaners:

Jif, Vim, Ajax, Chemico, Brasso, Oven Cleaners, neat Janola, wire wool, scourer pads, sandpaper.

Cleaning

- Wash down with warm water with a small amount of detergent. For best results use streak free glass cleaner with a soft cloth.
- For textured finishes (stipple, wood grain, etc) the periodic use of a soft brush may be necessary for the removal of dirt build-ups and residues left by some spray-on cleaners.

Spillages

- Hair rinse, Janola (neat), Harpic, oven cleaners - wash with hot soapy water then wipe dry.
- Fabric Dye - wash with cold water, then wipe dry. Then apply methylated spirits, and wipe dry.
- Battery acid, Hydrogen Peroxide, Glue Hardners - wash with cold water, then wipe dry.
- Hair Dye - wash with methylated spirits, then wipe dry.
- Leather Dye - wash with methylated spirits, then wipe dry. Follow with mineral turpentine wash and wipe dry.

Stain and Mark Removal

- Stubborn marks or stains - apply Handy Andy or diluted Janola (1 part to 3 parts water), then wipe down with a warm damp cloth.
- Smearing, finger marks, marking from cold or hot dishes, stickiness - apply 1 or 2 applications of acetone (available at pharmacies) and wipe over with dry cloth.

- Newsprint - use methylated spirits or mineral turpentine
- Rust - use vinegar or lemon juice
- Pencil - use water and a damp cloth
- Felt pen or dry marker - use methylated spirits or acetone
- Paint - use acetone or Duco Lacquer thinners (from a paint shop)
- Glue - contact type - use Ados Solvent N (from a paint shop)

Once again with any of the above use streak free glass cleaner to remove any residues.

Standard Colours



Thistle



Provence Blue

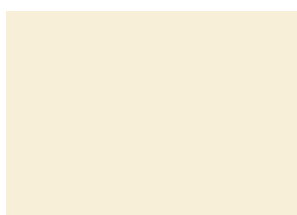

Antique Wiluna White



Seal Grey



Oyster



Iron Ore



Rock Salt



Brushed Silver



Carbon Vapour



Bullet



Elemental Concrete



Dansk Maple



Affinity Maple



NZ Tawa

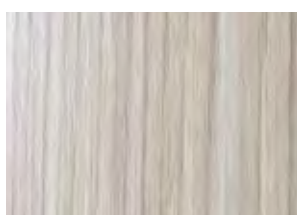

Aged Ash



Bliss Shitake

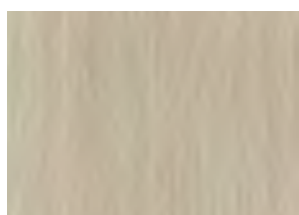

White Washed Oak



Smoke Strand

Powdercoating Colours



Grey Hammertone
Standard Colour for
Educational Furniture



Silver Star
Standard Colour for
Office Furniture



Graphite Ripple
Other powdercoating colours available on request
Surcharges may apply



Black Ripple

Please note that colours pictured are as close to specification as the printing process will allow.

Standard Colours



Provence Blue

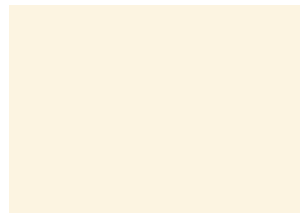

Antique Wiluna White



Seal Grey



White Washed Oak



Iron Ore

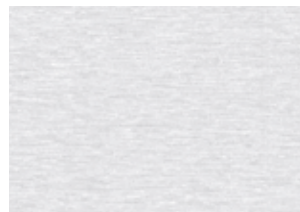

Rock Salt

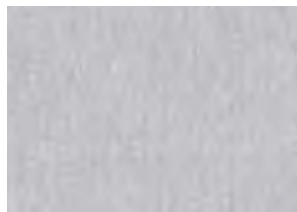

Brushed Silver



Smoke Strand



Carbon Vapour



Bullet



Bliss Shitake



Dansk Maple



Affinity Maple



NZ Tawa

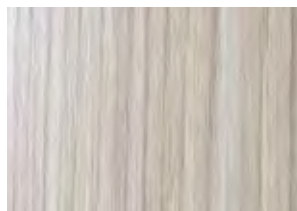

Aged Ash

Powdercoating Colours



Grey Hammertone

Standard Colour for
Educational Furniture



Silver Star

Standard Colour for
Office Furniture



Graphite Ripple

Other powdercoating colours available on request
Surcharges may apply



Black Ripple



63 South End Avenue, Whangarei 0110
PO Box 11089, Whangarei 0148

Contact us for a quote

E sales@educatedfurniture.co.nz

P 0508 645 397

educatedfurniture.co.nz